User Manual

ARRI ALEXA

**For ALEXA Software
Update Packet 2.0**

All rights reserved

The system contains proprietary information of ARRI; it is provided under a license agreement containing restrictions on use and disclosure and is also protected by copyright law. Reverse engineering of the system is prohibited.

Due to continued product development this information may change without notice. The information and intellectual property contained herein is confidential between ARRI and the client and remains the exclusive property of ARRI. If you find any problems in the documentation, please report them to us in writing. ARRI does not warrant that this document is error-free.

No part of this publication may be reproduced, stored in a retrieval system, or transmitted in any form or by any means, electronic, mechanical, photocopying, recording or otherwise without the prior written permission of ARRI.

Arnold & Richter Cine Technik
Tuerkenstr. 89
D-80799 Munich
Germany

[mailto: service@arri.com](mailto:service@arri.com)
<http://www.arri.com>

Contents

1	Disclaimer	4
2	Scope	7
3	ALEXA Images	8
4	Introduction to ALEXA	10
4.1	About This Manual.....	12
5	Safety Instructions	13
5.1	Explanation of Warning Signs and Indications.....	13
5.2	General Safety Instructions.....	13
5.3	Specific Safety Instructions.....	14
6	General Precautions	16
6.1	Storage and Transport.....	16
6.2	Electromagnetic Interference.....	16
6.3	Condensation.....	16
7	Power Supply	18
7.1	Power Management.....	18
7.2	BAT Connector.....	19
7.3	Mains Unit NG 12/26 R.....	19
7.4	Cine-Style Batteries.....	19
7.5	Onboard Batteries.....	20
7.6	V-Mount Batteries.....	21
7.7	Gold Mount Batteries.....	22
7.8	Power Outputs.....	23
7.8.1	12 V Accessories.....	24
7.8.2	24 V Accessories.....	24
8	Installation of The Camera	25
8.1	Minimum Equipment Recommended For Operation.....	25
8.2	Tripod and Remote Heads.....	25
8.3	Electronic Viewfinder EVF-1.....	26
8.3.1	Viewfinder Cables.....	27
8.3.2	Viewfinder Mounting Bracket.....	28

8.4	Center Handle CCH-1	30
8.5	Camera Side Handle CSH-1	31
8.6	Bridge Plate BP-12	32
8.7	Bridge Plate adapter BPA-1	33
8.8	Wedge Adapter WA-1 + Quick-Release Plate	33
8.9	Leveling Block LB-1	34
8.10	Shoulder Pad SP-3	34
9	Connectors	36
9.1	BAT	38
9.2	REC OUT 1&2	38
9.3	RET/SYNC IN	38
9.4	MON OUT	38
9.5	EXT	38
9.6	Ethernet	39
9.7	EVF	39
9.8	AUDIO IN	39
9.9	RS	39
9.10	12 V	39
9.11	TC	40
9.12	3.5mm TRS connector (Headphone Jack)	40
9.13	SD Card	40
9.14	SxS Slots	41
10	Optics	42
10.1	Lens Adapter PL Mount LA-PL-1 (no LDS)	42
10.2	Lens Support	43
11	Camera Controls	45
11.1	Main Controls	45
11.1.1	Display	46
11.1.2	Screen Buttons	46
11.1.3	Function Buttons	46
11.1.3.1	TC (Time Code)	47
11.1.3.2	INFO	49
11.1.3.3	USER	51
11.1.4	HOMESCREEN	53
11.1.4.1	Lists and User Lists	55
11.1.4.2	FPS	56
11.1.4.3	SHUTTER	60

11.1.4.4 EI	62
11.1.4.5 WB	63
11.1.5 Menu.....	65
11.1.5.1 Recording	65
11.1.5.2 Monitoring	69
11.1.5.3 Project.....	72
11.1.5.4 System.....	73
11.1.5.5 User Setups	76
11.2 Operator controls	76
11.3 EVF Controls	77
11.3.1 Viewfinder EVF menu	78
11.3.2 Viewfinder CAM menu.....	79

12 Operation of The Camera 79

12.1 Recording	79
12.1.1 Internal recording.....	79
12.1.2 External recording	84
12.1.3 Parallel recording	86
12.2 Monitoring	86
12.2.1 Framelines	87
12.3 Using Time code	89
12.4 Working with User Setups	90

Appendix 91

12.5 Technical specifications.....	92
12.6 Camera Dimensions.....	95
A.1 ALEXA Camera Accessory List	96
12.7 Infos and Warnings	98

13 Index 103

1 Disclaimer

Before using the products described in this manual be sure to read and understand all respective instruction.

The ARRI ALEXA is only available to commercial customers. The customer grants by utilization that the ARRI ALEXA or other components of the system are deployed for commercial use. Otherwise the customer has the obligation to contact ARRI preceding the utilization.

While ARRI endeavors to enhance the quality, reliability and safety of their products, customers agree and acknowledge that the possibility of defects thereof cannot be eliminated entirely. To minimize risk of damage to property or injury (including death) to persons arising from defects in the products, customers must incorporate sufficient safety measures in their work with the system and have to heed the stated canonic use.

ARRI or its subsidiaries do not assume any responsibility for incurred losses due to improper handling or configuration of the camera or other system components, due to sensor contamination, occurrence of dead or defective pixels, defective signal connections or incompatibilities with third party recording devices.

ARRI assumes no responsibility for any errors that may appear in this document. The information is subject to change without notice.

For product specification changes since this manual was published, refer to the latest publications of ARRI data sheets or data books, etc., for the most up-to-date specifications. Not all products and/or types are available in every country. Please check with an ARRI sales representative for availability and additional information.

Neither ARRI nor its subsidiaries assume any liability for infringement of patents, copyrights or other intellectual property rights of third parties by or arising from the use of ARRI products or any other liability arising from the use of such products. No license, express, implied or otherwise, is granted under any patents, copyrights or other intellectual property right of ARRI or others.

ARRI or its subsidiaries expressly exclude any liability, warranty, demand or other obligation for any claim, representation, or cause, or action, or whatsoever, express or implied, whether in contract or tort, including negligence, or incorporated in terms and conditions, whether by statute, law or otherwise. In no event shall ARRI or its subsidiaries be liable for or have a remedy for recovery of any special, direct, indirect, incidental, or consequential damages, including, but not limited to lost profits, lost savings, lost revenues or economic loss of any kind or for any claim by third party, downtime, good-will, damage to or replacement of equipment or property, any cost or recovering of any material or goods associated with the assembly or use of our products, or any other damages or injury of the persons and so on or under any other legal theory.

In the case one or all of the foregoing clauses are not allowed by applicable law, the fullest extent permissible clauses by applicable law are validated.

ARRI is a registered trademark of Arnold & Richter Cine Technik GmbH & Co Betriebs KG.

Note: This product and the accessories recommended by the manufacturer fulfill the specifications of the European Directive 2004/108/EC (15th December 2004).

The ALEXA viewfinder EVF-1 contains proprietary technology owned by Fourth Dimension Displays Limited and licensed by ARRI.

This product contains licensed technology from Linotype.

Quicktime and Quicktime logo are trademarks or registered trademarks of Apple Computer, Inc., used under license therefrom.

Apple ProRes 422, Apple ProRes 4444 and the ProRes logo are trademarks or registered trademarks of Apple Computer, Inc., used under license therefrom.

SxS and **SXS** are trademarks of SONY corporation.

This product meets CE regulations.

2 Scope

This instruction manual applies to the following ARRI ALEXA hardware, software and firmware versions:

ARRI ALEXA camera with ARRI EVF-1 electronic viewfinder

- Camera software update packet: 2.0
- EVF-1 software packet: 1.24

3 ALEXA Images



Figure 1: Camera right side



Figure 2: Camera left side



Figure 3: Camera top



Figure 4: Camera bottom



Figure 5: Camera front



Figure 6: Camera back

4 Introduction to ALEXA

ALEXA is a 35 format film-style digital camera made by ARRI, the world leader in professional cinematographic imaging. It combines leading edge digital technology with film camera features that have been refined over the more than 90 years of ARRI's history. The result is a camera that allows classic cinematographers to shoot digitally without the need for an excessive training when transforming from film.

People who are used to shoot digitally will experience a camera like they never did before, providing more powerful features than any other camera available today.

Handling

The camera is a true ARRI. It has a high-precision integrated camera housing with an ergonomic design. It is rugged, reliable and flexible. Sealed to make it splash-proof. It also has countless mounting points for accessories, as ALEXA integrates well with existing ARRI accessories. In addition, a new range of accessories specifically designed for ALEXA is available.

Operation

ALEXA features a unique user interface, designed to make camera operation easier than ever, while giving access to more controls than any camera before.

There are three different control interfaces:

- The Main user interface on the right side gives access to every camera parameter through a graphical display and a button panel.
- The Operator user interface on the left side for basic control, adjustable to the operator's individual needs by supplying assignable buttons in addition to function buttons.
- The viewfinder user interface for adjusting the most important image parameters with buttons on the viewfinder and the interface graphics overlaid to the viewfinder image.

Power management

The camera accepts any input voltage from 11-34 V DC. Different power sources can be connected to the camera simultaneously. The camera's power management ensures that the power source with the highest voltage level is used. Power sources are hot-swappable to minimize the risk of sudden power loss. Switching power sources without the need to reboot saves valuable time during a shoot.

ALEV III sensor

The ALEV III sensor has a horizontal pixel count of 3.5K resulting in true 2K resolution. It covers the full Super-35 format and it provides a latitude of 14 stops at a base sensitivity of 800 ASA. The result is a superior image quality.

The sensor temperature is kept stable by a Peltier element to ensure optimum image quality under all operating conditions.

AIT - ARRI Imaging Technology

ARRI imaging technology ensures the most organic, film-like image quality of any digital camera with natural color rendition and pleasing skin tones.

Thermal concept

The camera electronics are fully sealed to protect them from dirt and moisture. Camera heat is transported via heat pipes to a radiator which is cooled by a fan. The fan itself is very silent, so the camera noise level is below 20 dB (A)* - this is the same as with ARRI sync-sound film cameras. If the fan noise level starts to increase due to fan aging, the fan can be swapped in a matter of minutes by a trained technician.

*at 24 fps and ambient temperature < 25°C

EVF-1 electronic viewfinder

ARRI is redefining electronic viewfinders with LED lighting, high resolution and a viewing experience that comes as close to an optical viewfinder as possible.

Internal recording

ALEXA can internally record Quicktime movies with Apple ProRes codecs to Sony **SxS** cards. The cards deliver high data rates and are very robust. ProRes can be natively edited in FinalCutPro, eliminating the need to transcode. ProRes 422 (HQ) and ProRes 4444 deliver visually lossless compressed images with a color depth of 10 bit for ProRes 422 and 12 bit for ProRes 4444.

4.1 About This Manual

It is recommended that all users of the ALEXA camera read the manual front to back prior to the first usage. The manual's structure also provides quick access for reference to experienced users. All directions are given from an operator's point of view.

- Images: give a quick overview of the camera.
- Safety instructions / general precautions: very important - do not skip this part.
- Power supply: overview how the camera is supplied with power.
- Installation of the camera: information on camera mechanics.
- Connectors: what goes into the camera and what comes out.
- Optics: how to get a good image into the camera.
- Camera controls: how to set up the camera.
- Operation of the camera: gives examples and recommendations on camera operation.

5 Safety Instructions

Any violation of these safety instructions or non-observance of personal care could cause serious injuries (including death) to users and affiliates and damage to the equipment or other objects.

5.1 Explanation of Warning Signs and Indications



Indicates a possible risk of injury or damage to the equipment



Indicates the risk of electric shock or fire danger that could result in injury or damage to the equipment.

Note: Indicates further information or information from other instruction manuals

5.2 General Safety Instructions



- Always follow these instructions to ensure against injury to yourself or others and damage to the system or other objects.
- This safety information is in addition to the product specific operating instructions in general and must be strictly observed for safety reasons.
- Read and understand all safety and operating instructions before you operate or install the system!
- Retain all safety and operating instructions for future reference.
- Heed all warnings on the system and in the safety and operating instructions before you operate or install the system. Follow all installation and operating instructions.
- Do not use accessories or attachments that are not recommended by ARRI, as they may cause hazards and invalidate the warranty!
- Do not attempt to repair any part of the system! Repairs must only be carried out by authorized ARRI Service Centers.

5.3 Specific Safety Instructions



- Do not remove any safety measures from the system!
- Do not operate the system in areas with humidity above operating levels or expose it to water or moisture!
- Do not cover the fan openings at the camera back top and bottom!
- Do not subject the system to severe shocks!
- Do not place the system on an unstable trolley/hand truck, stand, tripod, bracket, table or any other unstable support device! The system may fall, causing serious personal injury and damage to the system or other objects.
- Operate the system using only the type of power source indicated in the manual! Unplug the power cable by gripping the power plug, not the cable!
- Never insert objects of any kind into any part of the system if not clearly qualified for the task in the manual, as objects may touch dangerous voltage points or short out parts! This could cause fire or electrical shock.
- Unplug the system from the power outlet before opening any part of the system or before making any changes to the system, especially the attaching or removing of cables!
- Do not use solvents to clean!
- Do not remove any stickers or paint marked screws!
- Always place a lens or a protective cap in the lens mount receptacle!
- Changing camera lenses should be done in a dry and dust-free environment. If this is not possible, take extra care that no dust enters the camera while the lens is off!
- When no lens is attached to the camera, immediately place the protective on the lens mount to avoid contamination of the sensor cover glass!
- After changing lenses, always perform a dust check to make sure no dust has settled on the sensor cover glass!
- Clean optical lens surfaces only with a lens brush or a clean lens cloth. in cases of solid dirt or grease, moisten a lens cloth with pure alcohol. Discard contaminated lens cloth after use! Never attempt to clean a lens brush with your fingers!
- **NEVER USE CANS WITH COMPRESSED AIR OR GAS TO BLOW OFF THE DUST!** This can severely damage optical elements.

- If the sensor cover glass has been contaminated by solid dirt or grease, special optical cleaning kits should be used for dirt removal under very high care! If the contamination cannot be removed, the camera should be taken to an ARRI service center for cleaning.
- NEVER USE METHANOL OR ACETONE TO CLEAN OPTICAL SURFACES!
- NEVER TRY TO REMOVE THE SENSOR COVER GLASS!
- DO NOT POINT THE CAMERA INTO DIRECT SUNLIGHT, VERY BRIGHT LIGHT SOURCES, OR HIGH-ENERGY LIGHT SOURCES (e.g. laser beams)! This may cause permanent damage to the camera image sensor.
- DO NOT POINT THE VIEWFINDER INTO DIRECT SUNLIGHT, VERY BRIGHT LIGHT SOURCES, OR HIGH-ENERGY LIGHT SOURCES (e.g. laser beams)! This may cause permanent damage to the viewfinder display and optical elements.

6 General Precautions

6.1 Storage and Transport

- To prevent damage to the optical filters and the sensor, a protective cap must be on the lens mount receptacle while no lens is attached.
- All cables have to be unplugged from the camera when it is transported or stored inside a camera case.
- Do not store the camera in places where it is subject to extreme temperatures, direct sunlight, high humidity, severe vibration, or near strong magnetic fields.

6.2 Electromagnetic Interference

Portable communication devices such as mobile phones or walkie-talkies may cause interference with video signals or even lead to malfunction of the camera. It is recommended to keep these devices turned off when near the camera.

6.3 Condensation



When moving the camera from a cool to a warm location or when the camera is used in a damp environment, condensation may form inside the lens compartment, on the sensor cover glass, between sensor and its cover glass, and on internal or external electrical connections.

- Operating the camera in these conditions may result in personal injury or damage to the equipment!

Condensation on the optical components may have a visible effect on the output images. To reduce the risk of condensation:

- Find a warmer storage location.
- Attach the ARRI air-drying cartridge (silica bottle) to the PL-Mount of the camera during storage (NOT during transport!)
- If camera needs to be stored in a place that is considerably cooler than the location where it will be used, consider keeping the camera powered from a mains unit in addition to using the air-drying cartridge.

- In ambient temperatures above 30°C/86°F and/or humidity above 60%, always attach the air-drying cartridge to the PL-Mount of the camera when not in use. This not only applies to storage, but also to shooting breaks and situations when the camera remains without an attached lens for an extended time.
- **MAKE SURE THE SILICA BOTTLE IS SECURELY FASTENED. UNDER NO CIRCUMSTANCES SPILL SILICA INTO THE LENS COMPARTMENT!**

7 Power Supply



- Only use recommended power supply solutions.
- Manipulation of power supplies can result in severe damage to the equipment and humans, including death.

ALEXA accepts an input voltage range from 11 to 34 V DC. The camera can be powered through the BAT connector or can be quipped with battery adapters accepting V-Lock or Gold Mount batteries.

The power supply should deliver an output of more than 90 W to power the camera sufficiently. The power draw of the camera in basic configuration is about 85 W.

Note: when powering accessories through the camera, the power draw of the camera is increased by the amount of power drawn by the accessories.

7.1 Power Management

When using the BAT connector and one or more onboard battery adapters simultaneously, the camera power management ensures that the power source with the highest voltage level is used. When the voltage level of one power source drops below the level of the other, or a power source is disconnected from the camera, the power management automatically switches to the other power source, avoiding shutdown of the system.

So as an example, one could use a 12 V onboard battery as backup for the main 24 V battery, or power the camera from the 24 V battery while on a tripod and use the 12 V battery for fast switching to handheld mode by just unplugging the power cable.

When using two onboard battery adapters with batteries in parallel, they are treated as one source by the camera. This allows combining small batteries with less load per item into one strong power source.

7.2 BAT Connector

The BAT connector of ALEXA is a Fischer 2-pin socket located on the bottom back of the camera right side.

The socket accepts power cables KC-20S and KC-29S. The cables can either be connected to the mains unit NG 12/26R or to 24V Cine-style batteries with three-pin XLR outputs.



Figure 7: BAT connector

7.3 Mains Unit NG 12/26 R

Use of the mains unit is recommended for shooting in the studio and when using electronic accessories with high power consumption.

- First check that the correct mains voltage is set on the mains unit (fuse on back of unit).
- Connect the mains unit to AC mains power.
- Ensure that the camera power is turned off.
- Set the voltage switch on the mains unit to 26 V.

Plug the battery cable KC-20S or KC-29S (spiral cable) into the power supply socket on the camera and into the 26 V socket on the mains unit.

Note: The NG 12/24 R was the original design that provided 12 & 24 volts output – it was superseded by the NG 12/26 R, which outputs 12 & 26 volts. The NG 12/24 R can easily be upgraded to NG 12/26 R specification at an ARRI service center.

7.4 Cine-Style Batteries

Any Cine-style battery with level of 24 V and a three-pin XLR out can be used to power the camera through a KC-20S or a KC-29S.

Available from ARRI is the battery CINE VCLX/2 battery (280 Wh) with charger.

To connect the battery to the camera:

- Ensure that the main switch on the camera is off.
 - Plug the battery cable KC-20S or KC-29S (spiral cable) into the power supply socket on the camera and the battery 28 V output socket.
-

Note: When the battery voltage drops below the warning level, the BAT1 level in the camera display will start flashing. A white "i" will appear, signaling more information is available on the INFO screen.

Note: For more information on setting the low battery warning level, see *Menu>System>Power* (on page 73).

Charging the battery

- Connect the charger to AC mains power.
 - Plug the charger cable into the charge input socket of the battery.
 - Once charged, batteries may be kept on the charger until required.
-

Note: For more information on CINE VCLX/2 battery and charger, please check the corresponding manual.

7.5 Onboard Batteries

The camera can be equipped with adapters for either V-Mount or Gold Mount video-style batteries.

The following two adapters are currently available:

- BAB-G: Back-mount adapter Gold Mount batteries
- BAB-V: Back-mount adapter V-Mount batteries

Two further adapters will be available soon:

- BAT-G: Top-mount adapter Gold Mount batteries
 - BAT-V: Top-mount adapter V-Mount batteries
-

Note: Adapters must be installed by a trained technician!

Anton Bauer Gold Mount batteries and ID-X V-Mount batteries transmit their remaining capacity to the camera, which is displayed in percent on the Homescreen of the camera display. For these batteries, the user does not need to set the battery warning level due to the communication between the camera and the battery.

7.6 V-Mount Batteries

V-Mount batteries are available from a number of manufacturers. V-Mount batteries from ID-X transmit information on their remaining capacity to the camera. ALEXA displays the remaining capacity in percent on the Homescreen of the camera display. For ID-X batteries, the user does not need to set the battery warning level due to the communication of camera and battery.

Attaching the battery to the adapter

- Place the battery with the V-shaped wedge into the adapter so that the wedge sits right above its counterpart of the mount.
- Move the battery downwards until you hear a snap.
- Make sure it is connected correctly and sits tight.

Releasing the battery

- When facing the battery, press the button located on the mount on the left side. Some batteries have an additional top-release mechanism.
- Move the battery upwards and remove it.



Figure 8: ALEXA with BAB-V and V-Mount battery

Note: Not all V-Mount batteries deliver enough power to supply the camera. We recommend to not use any batteries with a capacity of less than 90 Wh to prevent damage to the battery and unpredictable camera behavior. Any camera-battery combination should be tested prior to use, especially when accessories are powered through the camera.

7.7 Gold Mount Batteries

Gold Mount is the battery mounting system of Anton Bauer batteries. The batteries transmit information on their remaining capacity to the camera. ALEXA displays the remaining capacity in percent on the Homescreen of the camera display. For Gold Mount batteries, the user does not need to set the battery warning level due to the communication of camera and battery.

Attaching the battery to the adapter

- Place the battery with the three pins into the adapter so that the pins sit in the corresponding holes of the mount.
- Move the battery to the right until you hear a snap.
- Make sure it is connected correctly and sits tight.

Releasing the battery

- When facing the battery, move the lever located on the left side of the mount down.

- Move the battery left, then pull it towards you and remove it.



Figure 9: Camera with BAB-G and a Gold Mount battery

Note: Not all Gold Mount batteries deliver enough power to supply the camera. We recommend to not use any batteries with a capacity of less than 90 Wh to prevent damage to the battery and unpredictable camera behavior. Any camera-battery combination should be tested prior to use, especially when accessories are powered through the camera.

7.8 Power Outputs

The camera has three power outputs for accessories, 2x 24 V and 1x 12 V.



Figure 10: 24 V outputs (RS) and 12 V output

7.8.1 12 V Accessories

The 12 V output is located on the right side of the camera. It has a 2-pin LEMO connector and can supply a device with a current of up to 2.5 A, depending on the camera power supply.

7.8.2 24 V Accessories

Two RS outputs are located on the right side of the camera. They have a 3-pin Fischer connector. They can supply two devices with a combined load of up to 2.5 A, depending on the camera power supply. When the camera is powered from a source with a voltage below 24V, they output 24V. If the camera's power source is supplying more than 24V, this voltage level is also present on the RS outputs.

Besides powering accessories, these sockets can also be used to send a remote start+stop signal to the camera.

8 Installation of The Camera

8.1 Minimum Equipment Recommended For Operation

- ARRI ALEXA body including DTE-SxS module and lens adapter PL mount (LA-PL-1)
- EVF-1 electronic viewfinder
- VMB-1 viewfinder mounting bracket
- KC 150-S viewfinder cable short 0.35m/1.2ft
- CCH-1 center camera handle
- BP-12 bridge plate with base plate, or BPA-1 with BP-5/BP-8 bridge plate and base plate, or WA-1 and quick-release base-plate
- SD card
- Compatible power supply
- Sony **SxS**-Pro card for recording

8.2 Tripod and Remote Heads

Tripod and remote heads used with ALEXA have to provide enough load capacity to support the camera and attached accessories. The table to the right shows the camera weight for different components.

Note: Check for the payload of remote heads and cranes.

- In applications where the camera mount is subject to high forces (e.g. car or helicopter mounts) the camera must be additionally secured with retaining cords. All fastening screws must be tightened firmly with an appropriate screwdriver (not with the commonly used coin!).

Camera weight	lbs	kg
ARRI ALEXA incl. SxS module, EVF-1, VMB-1, CCH-1	17.62	8.0
ALEXA camera body including SxS module	13.79	6.26
EVF-1	2.42	1.1
VMB-1	0.55	0.25
KC-150S	0.26	0.12

Handle CCH-1

0.6

0.27

8.3 Electronic Viewfinder EVF-1



The EVF-1 employs an LCOS imaging device together with a temperature stabilized LED light source to provide an accurate and bright view of the sensor image under all operating conditions. The viewfinder is calibrated to match the image of the camera's HD outputs.

The image area of the EVF-1 has a size of 1280x720 pixels. 32 additional pixels each above and below the image provide two status bars for displaying camera information. The EVF-1 can display the 10% surround view area of the sensor to help the operator track unwanted elements before they enter the recorded image area. Focus can be checked by temporarily zooming into the image center with a magnification of 2.25x. The low-latency interface of the EVF-1 has a delay of less than 1 frame.

The viewfinder is connected to the camera with the mounting bracket VMB-1.



Figure 11: Camera with EVF

Note: Do not point the viewfinder eye-piece at direct sunlight or bright light sources, as this could damage the LCOS imaging device. If possible, cover the eye-piece when not in use to prevent any damage.

8.3.1 Viewfinder Cables

The viewfinder cables are unidirectional with a male plug to connect to the camera and a female plug to connect to the EVF.

Cables are available in the following lengths:

Model	Length (m / ft)	Purpose
KC-150-S	0.35 / 1.2	For use of EVF-1 on camera left side in handheld mode
KC-151-S	0.65 / 2.1	For use of EVF-1 on camera right side or when using Viewfinder Extension Bracket VEB-1
KC-152-S	2.00 / 6.6	Longest possible length for use with specialty rigs



Figure 12: EVF cables: KC-150S (center), KC-151S (middle), KC-152S (outer)

8.3.2 Viewfinder Mounting Bracket

The viewfinder mounting bracket VMB-1 is attached to the camera with two 3mm hex screws at the very front of the camera top. The viewfinder is attached to the mounting bracket by sliding the dove tail into the receptacle of the mounting bracket and then closing the lever on the viewfinder.

The position of the viewfinder can be adjusted by loosening the levers of the mounting bracket, adjusting the position as desired and closing the levers.

It can be flipped over by first unscrewing the cap at the end of the side adjusting rod, then removing the rod itself and inserting it into its mount from the other side. Then reattach the cap.

Note: Camera right operation is not possible with the standard EVF cable KC-150-S. Instead, the longer cable KC-151-S is needed.



Figure 13: VMB-1 on camera

The viewfinder extension bracket VEB-1 extends the mounting point of the EVF further back. It can be attached to a tripod head for use with geared heads or greater comfort when using fluid heads. The VEB-1 has a standard attachment point for the ARRI eyepiece leveler EL-3.



Figure 14: EVF extension bracket



Figure 15: Camera with EVF-1 on extension and cable KC-151S

8.4 Center Handle CCH-1

The center handle CCH-1 is attached to the camera top with 3 screws, two at the front and one at the back. Make sure the screws are well tightened with a 3mm allen key.



Figure 16: Camera with CCH-1, side view



The handle extension block HEB-2 mounts to the front end of the CCH-1 and adds one more focus hook to the camera in a high position, so the tape measure clears the matte box.



8.5 Camera Side Handle CSH-1

The CSH-1 is used in conjunction with a BAT-V or BAT-G battery top mounting adapter, or with third-party onboard recorders. It is attached to the camera with 3 screws, two at the front and one at the back. Make sure the screws are tightened firmly with a 3 mm allen key.

If a tall battery or a tall third-party onboard recorder is used, the adjustable center grip of the CSH-1 can be replaced by the taller Adjustable Center Grip Tall (ACG-2).



Figure 17: CSH-1



Figure 18: Camera with CSH-1, side view

8.6 Bridge Plate BP-12

The bridge plate BP-12 has been newly developed for ALEXA. It mounts directly to the camera housing with two screws.



8.7 Bridge Plate adapter BPA-1

The bridge plate adapter BPA-1 can be used to attach a BP-5/BP-8 to ALEXA. First attach the BPA-1 to the camera with the two screws. Then attach the BP-5/BP-8 to the adaptor with its two screws. Make sure the screws are tightened firmly with a screwdriver.



8.8 Wedge Adapter WA-1 + Quick-Release Plate

The WA-1 can be mounted to the same position as a bridge plate. It has a dove tail that slides into the counter part of a quick-release plate, like the QR-HD-1. The quick-release plate has a pin at its back, which fits into the pin receptacle at the back of the camera base.



Figure 19: ARRI QR-HD-1

8.9 Leveling Block LB-1

The leveling block LB-1 attaches to the bottom of the ALEXA back foot. It prevents the camera from resting on a back mounted battery when placed on a flat surface.

It is mounted by inserting its top lid into the pin receptacle on the end of the shoulder arc in the camera base. Twist the knob clockwise to tighten.



Figure 20: Leveling Block LB-1

8.10 Shoulder Pad SP-3

The camera base has an integrated arch to fit to the operator's shoulder. For extended handheld shoots, the newly designed shoulder pad SP-3 can be attached to the base of the camera with velcro.

Note: The SP-3 can only be used with a BP-12 and 19 mm rods or with 15 mm rods and a WA-1+quick-release base plate. When using the BPA-1 with a BP-5/BP-8, the bridge plate has to be removed prior to attaching the SP-3.



Figure 21: SP-3 shoulder pad



Figure 22: SP-3 below camera

9 Connectors

Camera back



Figure 23: Connectors at back

From top to bottom: MON OUT, RET/SYNC IN, EXT, REC OUT 1&2, BAT, ETHERNET

Camera right



Figure 24: Connectors on right side

From left to right, top to bottom: 2x RS (24 V) out, AUDIO OUT, TC, 12V out, AUDIO IN, SD CARD (camera bottom)

Camera left



Figure 25: Camera left: SxS slots

Top to bottom: SxS slot 1, SxS slot 2

Camera front



Figure 26: Camera front connector

EVF connector

9.1 BAT

The BAT connector can be used to power the camera from an external power source with cables KC-20S and KC-29S.

It is located on the camera back lower right.

9.2 REC OUT 1&2

The REC OUT consists of two BNC plugs capable of carrying 1920x1080 1.5G HD-SDI signals with frame rates from 23.976 to 60 fps according to SMPTE standards 274M, 292M and 372M. The signal format can be changed in the camera menu.

It is located on the camera back mid right.

9.3 RET/SYNC IN

This BNC connector is currently not in use.

It is located on the camera back mid right.

9.4 MON OUT

The MON OUT is a single BNC connector capable of carrying a 1920x1080 422 YUV 1.5G HD-SDI signal with frame rates of 23.976, 24, 25, 29.97 or 30 fps according to SMPTE standards 274M and 292M. The signal format can be changed in the camera menu.

It is located on the camera back upper right.

9.5 EXT

The EXT connector is a multi-pin accessory connector. It carries signals for communication with various accessories.

Cables are currently available for:

- Connecting a UMC-3 remote motor controller

The connector is located on the camera back mid right.

9.6 Ethernet

Regular Ethernet connectors do not deliver the durability and reliability required by ARRI, so ALEXA uses a 10-pin LEMO connector. A special cable, available from ARRI (model KC-153-S), is required to connect the Ethernet socket to a standard RJ-45 Ethernet socket. In addition, the Ethernet port is used for service and future accessories.

It is located on the camera back lower right.

9.7 EVF

The EVF connector connects the camera to an EVF-1 electronic viewfinder. The signals on this connector are proprietary and can only be used to drive an EVF-1. This proprietary signal assures very low latency for the viewfinder image.

It is located on the camera front lower left.

9.8 AUDIO IN

The 5-pin XLR Audio connector is currently not in use.

It is located on the camera right lower front.

9.9 RS

The two RS connectors supply external accessories with at least 24 V power and combined load of up to 2.5 A. The sockets also accept an ARRI remote start/stop trigger button.

They are located on the camera right lower front.

9.10 12 V

The 12 V connector supplies an external accessory with 12 V power and up to 2.5 A current.

It is located on the camera right lower front.

9.11 TC

The TC connector is a 5pin LEMO socket. It accepts and distributes LTC time code signals.

It can be used to

- Jam sync the camera time code to a Clockit, TC Slate or another camera
- Transmit the camera's time code to Clockit, TC Slate or another camera
- Tune the camera crystal oscillator's frequency with an Ambient ACC Clockit Controller

It is located on the camera right lower front.

9.12 3.5mm TRS connector (Headphone Jack)

The 3.5mm TRS connector (headphone jack) is currently not in use.

It is located on the camera right lower front.

9.13 SD Card

The SD card slot is located at the bottom on the camera right side middle. Any SD or SDHC card with a capacity of up to 4 GB can be used. The card must be pre-formatted with an FAT or FAT32 file system. The slot is protected from dirt and rain by a slider door. Insert the SD card according to the drawing on the camera housing.

Note: Always keep the slider door closed during operation to prevent dirt and moisture from entering the camera.

On the SD card, the following folder structure should be created by the user prior to first use of the card:

- ARRI
 - ALEXA
 - Firmware
 - Framelines
 - Setups

9.14 SxS Slots

On the camera's left side are two **SxS** card slots. They are behind a door that can be opened by pulling the top lid backwards. The door opens towards the camera housing for permanent accessibility even in tight spaces or on special rigs. Make sure the door is always closed to prevent moisture and dirt from entering the camera!

The cards are inserted with the card contacts first and the **SxS** labeled side outwards. They have to be pushed inwards against a spring until they lock in place. Make sure the cards are locked before closing the door, or the cards could be damaged.

To release a card, push it inwards until it is unlatched. The spring will push the card outwards. Be careful that the card does not drop out of the slot!

Cards do not have to be mounted or unmounted. They can be ejected whenever the camera is not writing to the cards. Even if cards are ejected during record, they maintain their functionality with the last take intact, except that the last three seconds of the take are lost.

Note: If a writing process is interrupted by power loss or card eject, remove the card from the camera, copy all data from the card and format the card before using it again.

A card select button is located between the card slots. By pushing it, the currently active card can be toggled.

Each card has an LED that signals the card state to the user.

LED state	Card state
Off	No card present
	Card is unreadable (e.g. wrong file system)
	Card is inactive
Solid green	Card is selected and ready
Solid red	Card is accessed (read/write)
	!DO NOT REMOVE CARD!

Currently only **Sony SxS-Pro** cards can be used with ALEXA. **Sony SxS-One** cards are not supported yet.

10 Optics

ALEXA is equipped with an exchangeable lens mount. By using different adapters, not only PL-mount lenses are supported, but a wide range of Cine and still photo lenses.

Note: Lenses must cover an image circle of at least 30 mm diameter to eliminate the risk of vignetting

10.1 Lens Adapter PL Mount LA-PL-1 (no LDS)

The lens adapter LA-PL-1 is the standard lens mount delivered with ALEXA. It can be used to attach any PL-mount lens to the camera.

Attaching a lens to the camera

- Twist the bayonet ring handle anti-clockwise as far as it will go.
 - Remove the protective lens cap.
 - Insert the lens into the lens mount receptacle without catching it at the edges. One of the four slots on the lens mount must fit over the index pin in the lens mount receptacle.
 - Choose a lens position that gives a good readability of lens markings.
 - Press the lens flat onto the lens mount receptacle.
 - Twist the bayonet ring handles clockwise until the lens is attached.
 - Make sure the lens is properly mounted.
-

Note: When no lens is attached to the camera, use the protective cap to avoid dust entering the lens cavity.

Note: The sophisticated design principle of the camera's optical module delivers outstanding images with a cinematic look and feel, but also makes the imager sensitive to contamination. Dust particles that have settled on the sensor cover glass during a lens change may become visible as dark spots in the output image, similar to lint leaving marks on exposed film. The degree of this effect depends on the aperture of the lens.

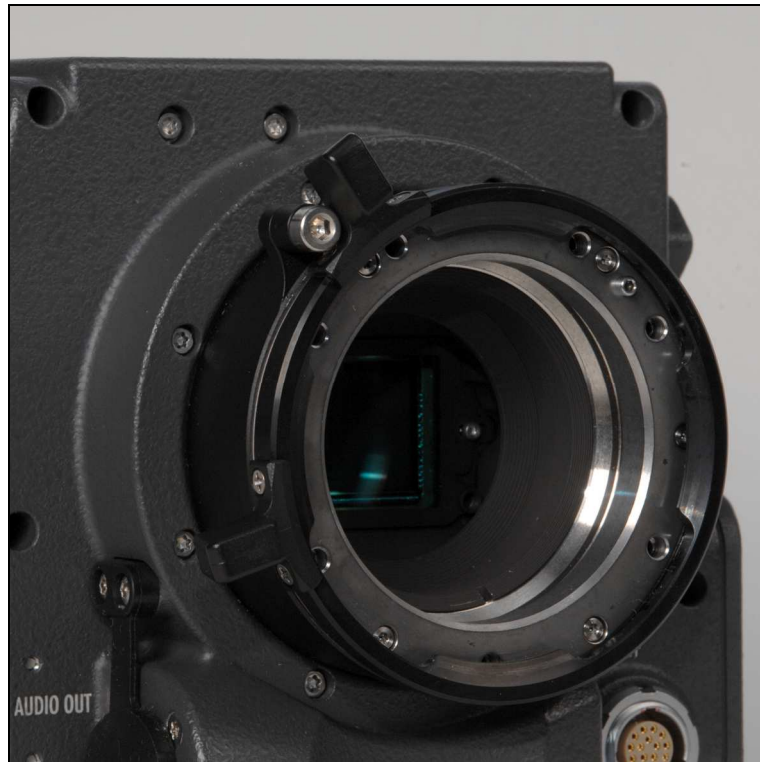

Figure 27: PL mount LA-PL-1 with index pin

10.2 Lens Support

Heavy lenses may require additional lens support. This guarantees that the flange focal depth is not influenced by the lens weight and reduces stress on the lens mount.

To support a lens, use 15mm or 19mm rods and a fitting lens bridge. 15mm rods can be directly inserted into the camera housing. 19mm rods require a bridge-plate with 19mm rod support (BP-12 or BP-5/BP-8 + BPA-1).

The lens bridge LS-10 for 15 mm rods is mounted to the rods by pushing it on the rods from the front, while the lens bridge LS-9 for 19 mm rods is mounted to the rods by pushing it on the rods from the top.

When the bridge is in the right position on the rods, it is fixed with the screw or lever on its side. It is attached to the lens support ring with its center screw. The lever on the back of the lens bridge fixes the height of the center screw.



Figure 28: Camera with BP-12, 19mm rods and lens bridge

11 Camera Controls

The camera can be controlled through three different interfaces:

- **Main controls:** Located on the camera right side. Consist of a 3" LCD-screen with screen buttons changing their behavior depending on the screen content, a jogwheel to navigate through menus and adjust parameters and a range of function buttons with dedicated behavior.
- **Operator controls:** Located on the camera left side. Consist of three assignable function buttons plus three function buttons for quick-and-easy operator interaction.
- **EVF controls:** Located on the electronic viewfinder. Allow adjustment of viewfinder parameters and the most important image related parameters.

11.1 Main Controls

The main controls can be used to set all camera parameters.



Figure 29: Main user interface

11.1.1 Display

The LCD display on the right side has a diameter of 3" and a resolution of 400x240 pixels. The display is back illuminated and transfective which results in exceptional contrast even in bright sunlight. The brightness of the display can quickly be adjusted by simply turning the jogwheel when the Homescreen is displayed.

The removable protective plastic shield protects the display from scratches and can simply be removed by pulling it off the four pins on its corners that hold it in place.

11.1.2 Screen Buttons

Six screen buttons are located above and below the display. They change their behavior depending on the screen content. The function related to each button in a screen is shown by a black label in the screen located below or above the button. Buttons without a black label have no function in that screen.

Operations that cannot be reversed and can result in the loss of data require the simultaneous pressing of two buttons to prevent them from accidental use.

11.1.3 Function Buttons

The main controls feature the following function buttons:

- ON/OFF: Press shortly to switch the camera on. To switch off the camera, the button must be pressed for several seconds. In the Homescreen, a countdown is displayed. If the button is released before the countdown has elapsed, the camera does not shut down. When a power source is connected to the camera, the ON/OFF button flashes once per second when the camera is switched off.
- REC: Starts/stops internal recording to **SxS** cards.
- LOCK: Press long to lock the user interface. Locking the camera also loads the Homescreen. Buttons USER, REC, HOME and ON/OFF are not affected by the lock.
- GRAB: Currently not in use.
- TC: Enters the screen for configuring Time code.
- PLAY: Loads a list of all clips on the mounted **SxS** cards. Playback from cards is currently not possible.
- INFO: Enters the Status Info screen, where you get information on the system's state. Also available is version info, where you get information on camera hard- and firmware, storage info giving details about **SxS** cards, and system info.

- **USER:** Enters the user screen, where you can assign the three user buttons of the operator controls, as well as the six screen buttons of the user screen (Note: the top three screen buttons of the user screen reflect the behavior of the three user buttons that are part of the operator controls).
- **MENU:** Starts the menu, where most camera settings can be adjusted. Navigate inside the menu with the jogwheel.
- **BACK:** When navigating, this button brings you back to the previous screen. When editing, this button reverts your adjustment and quits edit mode.
- **HOME:** Returns to the Homescreen from any other screen.

11.1.3.1 TC (Time Code)

The TC screen shows the currently set TC. By pressing the OPTIONS screen button, the time code Options list opens, where TC settings can be changed.

The currently active TC settings are displayed below the TC values.

- **Source:** Choose the TC source
 - Int TC: internal TC counter
 - Ext LTC: TC is read from the LTC input. Only possible with Mode set to Free Run, and the project fps must match the sensor fps setting!
 - SDI LTC: currently not supported
 - SDI VITC: currently not supported
- **Mode:** Defines how the TC is counted
 - Rec Run: TC will only increment during record.
 - Free Run: TC is running free. If the source is set to Int TC, and the sensor frame rate does not match the time base of the TC, the value is incrementing with every new frame generated by the sensor while counting with the set time base (=project fps).
- **Generator:**
 - Regen: Rec Run TC is regenerated from the last valid TC value.

With Ext LTC, it means that the camera is continuously reading the TC signal at the LTC socket as long as it is present. Only upon disconnection or loss of signal, the camera continues counting on its own. When the external signal reappears, the camera uses the values of the external signal again.

With Int TC, the value is increased with each new image generated by the sensor.

- **Jam sync:** Only Ext LTC can be jam synced. This means that the external TC source is connected to the camera, then the camera reads the external TC count and continues counting on its own. Due to a highly precise crystal oscillator in ALEXA, the internal counter will count accurately for 8 hours. After that period, the camera has to be resynced to avoid any TC offset.

Note: It is recommended to sync after every shooting break to avoid the risk of having to resync during the shoot.

Note: The camera will keep its TC for about 10 minutes after disconnection from the power source. If a power source is connected, the camera will remember its TC for as long as the power source is connected, even if it is switched off.

- Userbit source: shows the source of the user bits.
 - Internal: User bits are set manually in the User Bit screen.
 - LTC in UB: When using Ext LTC as TC source, the user bits are sampled from the external signal.

Press the SET TC screen button to adjust the TC counter (only with Int TC as source). Reset it or match it to the system clock with the upper screen buttons that appear during edit mode.

Press the USER BITS screen button to access the USER BITS screen.

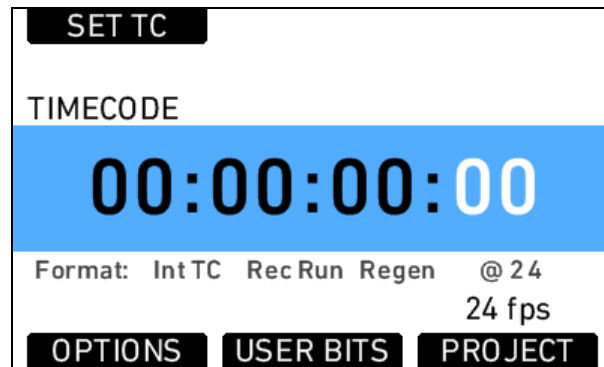

Figure 30: Timecode screen

Note: The camera will force Time code to "Internal Rec Run Regenerate" if the sensor fps does not match the project fps!

The PROJECT button is a quick link into the PROJECT menu screen, where project fps can be adjusted. Project fps sets the time base of the time code.

Note: Non-integer TC time base settings 23.976 and 29.97 are currently always counted as non-dropframe time code!

USER BITS

The content of the User binary group in the time code. Can contain 8 letters of Hex values (0-9, A-F).

Press the SET UB screen button to adjust the User Bits values.

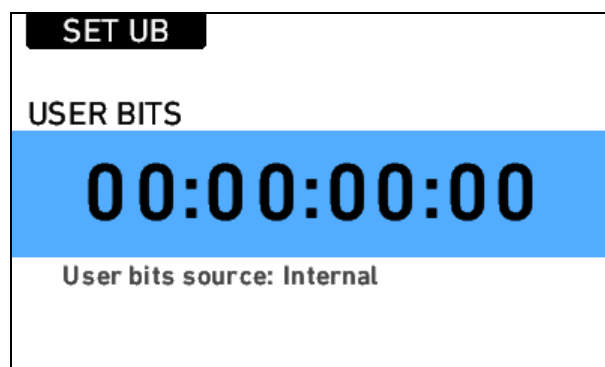

Figure 31: User bits screen

Note: User bits are currently not embedded in SDI out.

11.1.3.2 INFO

STATUS Info

The first INFO screen contains information on the current state of the camera system. If the camera behaves normally, the message "System state: Good" is displayed. Other messages can either contain a warning or an error message.

When an SD card is present, a system log can be stored to the SD card by pressing the lower mid screen button labeled SAVE TO SD. Patience is required as it can take about a minute until the log is written to the SD card.

Note: Saving a system log is only necessary if the camera is showing unnormal behavior. It can then be sent to the ARRI camera service for analysis. The log is not human-readable and can only be analyzed by the ARRI camera service.



VERSION Info

- Cam serial no.: the serial number of this camera

- Cam ID: translation of the camera serial number to Base36, with an additional prefix for 3D applications
- Firmware: version number of the camera firm- and software packet
- EVF serial number: the serial number of the EVF attached to the camera
- EVF firmware: version number of the EVF's firmware.

STATUS	VERSION	SxS CARDS
Cam serial no.		2010
Cam ID		1JL
Firmware		2.0Beta
EVF serial no.		16
EVF firmware		1.24
SYSTEM		

Figure 32: VERSION info screen

SxS CARDS Info

- Codec: currently set codec for internal recording
- Status: current status of SxS cards in slot 1 and 2
- Free capacity: free storage space of SxS cards in percent
- Write speed: maximum write speed of the SxS cards. Determined by camera during format.

STATUS	VERSION	SxS CARDS
Codec		ProRes 422 (HQ)
	SxS 1	SxS 2
Status	Stby	Empty
Free capacity	80%	0%
Write speed	450 Mb/s	0 Mb/s
SYSTEM		

Figure 33: SxS CARDS info screen

SYSTEM Info

- Date: currently set date. Can be set in MENU>SYSTEM>DATE/TIME.
- Time: currently set time. Can be set in MENU>SYSTEM>DATE/TIME.
- Fan speed: speed of camera cooling fan in rotations per minute.

- IP address: IP address of the camera's Ethernet port.

STATUS	VERSION	SxS CARDS
Date	2010- 07-20	
Time	12:00:00	
Fan speed	0 rpm	
IP address	169.254.1.24	
SYSTEM		

Figure 34: SYSTEM info screen

11.1.3.3 USER

By pressing the USER button the USER screen is loaded where the screen buttons can be assigned with user defined functions.

The upper three screen buttons of the USER screen mirror the behavior of the three assignable buttons on the camera left side (labeled 1, 2, 3). The two outer lower screen buttons function as additional assignable buttons with extended functionality.

By pressing the lower right EDIT screen button, the functions can be assigned to the buttons.

1	2	3
None	None	None
USER BUTTONS		
None	None	
4	5	EDIT

Figure 35: User screen

Assign functions to the buttons by using the jogwheel.

1	2	3
Button 1		None
Button 2		None
Button 3		None
Button 4		None
Button 5		None
4	5	DONE

Figure 36: Edit User Button assignment

For user buttons 1-3, which are also available on the camera left side, the following functions can be assigned:

Name	description
None	button has no function
Mon out surround	toggles surround view of the MON OUT image on/off
Mon out gamma	toggles gamma of the MON OUT between REC 709 and log C (only with recording gamma set to log C)
Mon out frame lines	toggles frame lines of the MON OUT image on/off
Mon out status info	toggles status info of the MON OUT image on/off
Frame lines color	toggles color of frame lines image on/off
EVF surround view	toggles surround view of the EVF image on/off
EVF gamma	toggles gamma of the EVF image between REC 709 and log C (only with recording gamma set to log C)
EVF frame lines	toggles frame lines of the EVF image on/off
EVF status info	toggles status info of the EVF image on/off

User buttons 4 and 5 have two additional functions

Name	description
Format Card 1	quick link to the menu screen where SxS card 1 can be formatted
Format Card 2	quick link to the menu screen where SxS card 2 can be formatted

11.1.4 HOMESCREEN

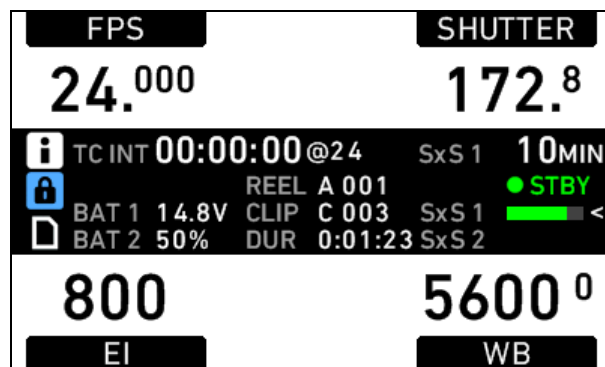

Figure 37: BETA Homescreen

The HOMESCREEN is the default screen of the main UI. It shows the most important camera parameters and gives quick access to changing them through the screen buttons.

Screen content

Screen Buttons

- **FPS:** Currently set frame rate of sensor, adjustable from 0.750-60.000 fps.
- **SHUTTER:** Currently set shutter angle of sensor, adjustable from 5.0-358.0°. Shutter Angle and sensor fps determine exposure time of the sensor in seconds by the following equation:
$$\text{Angle}/(360*\text{Fps})$$
- **EI:** Currently set exposure index rated in ASA. ALEXA has a base sensitivity of 800 ASA, the camera rating can be adjusted from 160-1600 ASA.

Note: ASA rating is identical to ISO rating.

Note: Exposure Index is not applied to Arriraw signals.

- **WB:** Camera white balance. This is the color temperature of the light source the camera is currently adjusted for. Can be adjusted from 2000-11000 Kelvin. In addition to the red/blue correction of the white balance, ALEXA can also compensate for a green/magenta tint. This value, called CC (after color compensation), is shown as an exponent of the WB value. Positive values are marked with a "+" and negative values with a "-".

Center Info Bar

- **TC:** Displays current time code including source (INT=internal or EXT=external source). Frames are not displayed, instead the timebase of the time code is shown in small digits.
- **REEL:** Identifies current reel (=SxS card name). Consists of camera index and reel counter.
- **CLIP:** Identifies current clip. Consists of Clip index and clip counter.
- **DUR:** Duration of current clip during recording or length of last recorded clip during standby. Shown as h:mm:ss.
- **CARD section:** Displays capacity information of SxS cards.

Top: Capacity of currently active card in minutes. Calculated for currently set framerate and codec.*

Bottom: Green capacity bar showing remaining capacity in percentage. Grey if card slot is empty. Red if card cannot be recorded. In this case, see INFO screen for more details.

<: Marks the active card.

-  State of camera is shown below the remaining recording time.

* Note: The value that is shown is the minimum available recording time. As Apple ProRes, the codec family used for image encoding in ALEXA, is a variable bit rate codec, the available recording time depends on the image content. It can well be that the available recording time exceeds the value displayed here.

- Icons: Icons inform the user about the system state.
 - Info: Shows that important information is waiting on the Info screen. White icon signals warning, red icon signals error.
 - Thermometer: informs about a sensor temperature problem. White icon signals small temperature offset (slightly reduced image quality), red icon signals high temperature offset (significantly reduced image quality).

Note: A sensor temperature warning or error after bootup is normal until the sensor has reached its preset temperature.

- Lock: Signals that the UI is locked. Not all buttons are affected. buttons that still work: USER, HOME, REC, ON/OFF
- SD card: Signals that an SD card is present. The color changes to orange while the card is accessed (read/write).

All icons of the Homescreen (from left to right: Info white/red, Thermometer white/red, Lock, SD card):



11.1.4.1 Lists and User Lists

The HOMESCREEN screen buttons FPS, SHUTTER, WB (White Balance) and EI (Exposure Index) open screens with lists that contain preconfigured values for the respective setting.

Except for EI, all lists are user lists where the user can store a selection of his preferred settings for quick access.

To select a preset, turn the jogwheel until the selection bar is on the desired value and press the jogwheel.

Note: In the FPS list, selection of frame rates higher than 30 fps are disabled if an SxS card is inserted. Frame rates of 30-60 fps for recording with external devices can only be set if no SxS card is present.

If the list lacks the required setting, press the ADD screen button. This opens a screen where the desired value can be set. Either by using the jogwheel for in- or decrementing the value, or additionally use the screen buttons for bigger adjustment steps.

When the desired value is set, press the jogwheel to add the value to the list.

Note: A maximum of 16 entries is supported by the list. After reaching this number of entries, it is no longer possible to add entries without deleting others first.

List values no longer required can be deleted by pressing the DELETE screen button. This opens a screen where the values desired for deletion can be selected with the jogwheel. To delete the selected value, press the two lower outer screen buttons simultaneously.

Note: Every list contains standard values that cannot be deleted. These values are grayed out in the DELETE screen.

Note: The EI list is static and cannot be changed by the user. It contains ASA values from 160-1600 ASA in steps of 1/3 stop.

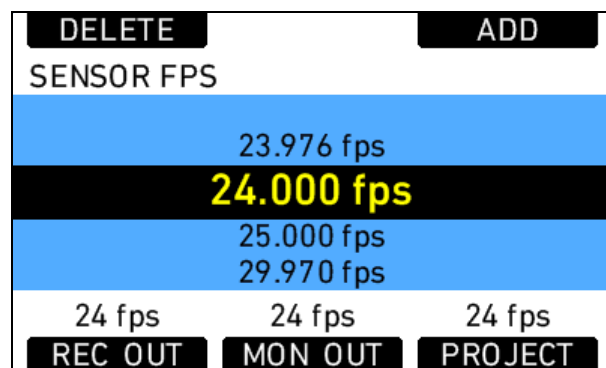

Figure 38: List example: User list fps

11.1.4.2 FPS

Pressing the FPS screen button opens the FPS list screen. It contains the default frame rates 23.976, 24.000, 25.000, 29.970, 30.000, 48.000, 50.000, 59.940 and 60.000 fps.

Note: Access to this screen is disabled during record.

The user can store a selection of his preferred fps settings for quick access. To select an fps preset, turn the jogwheel until the selection bar is on the desired value, then press the jogwheel again.

The screen buttons on the screen bottom are shortcuts to the menu screens of REC OUT, MON OUT and PROJECT, where their frame rates can be adjusted to match the sensor fps.

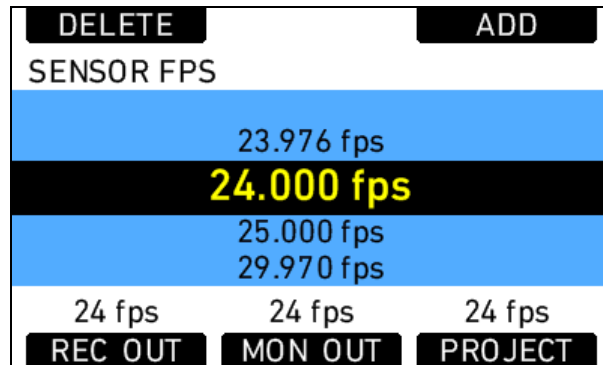
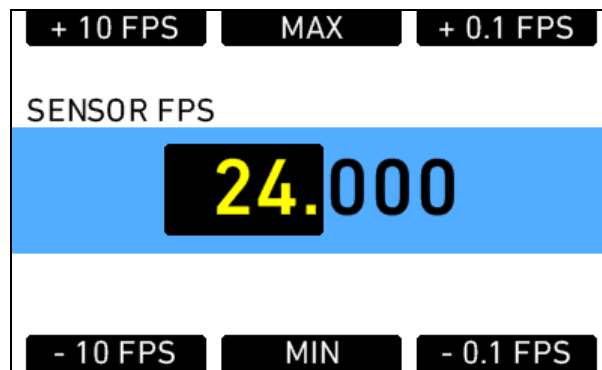

Figure 39: List example: User list fps

If the list lacks the required setting, press the ADD screen button. This opens a screen where the desired setting can be set. Either use the jogwheel to set the desired value, or additionally use the screen buttons for bigger adjustment steps. When the desired value is set, press the jogwheel to add the value to the list.

Note: A maximum of 16 entries is supported by the list. After reaching this number of entries, it is no longer possible to add entries without deleting others first.



List values no longer required can be deleted by pressing the DELETE screen button. This opens a screen where the values desired for deletion can be selected with the jogwheel. To delete the selected value, press the two lower outer screen buttons simultaneously.

Note: Default frame rates cannot be deleted.

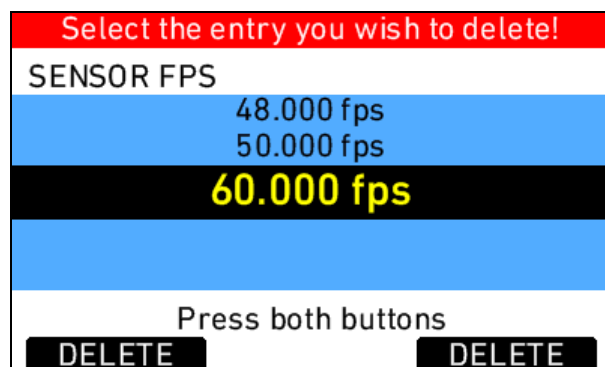

Figure 40: Delete fps list entry

If the sensor fps is linked to the REC OUT frame rate, a message appears instead of the list. While this setting is active, sensor fps can only be changed by changing the REC OUT frame rate.

To change this setting, press the REC OUT screen button to access the REC OUT menu screen and set "Link sensor fps" to "Off".

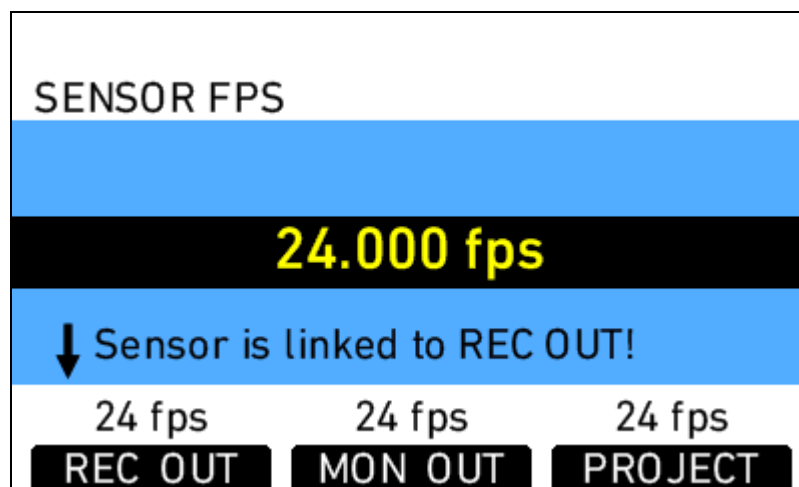

Figure 41: Fps screen with linked sensor fps

Setting correct frame rates for recording with external devices

It is very important to pay good attention to setting frame rates when recording with external devices. Mistakes can result in dropped frames and ruin the shot.

The sensor fps setting determines the amount of frames per second generated by the sensor. This can be anywhere in the range between 0.750 and 60.000 frames per second. The images are then processed by the camera electronics for the different output paths.

The REC OUT is the recording output path. It is connected to an external recorder where the images are stored. Its frame rate can only be set to standard speeds. The REC OUT frame rate must match the Sensor frame rate! If the REC OUT frame rate is lower than the sensor frame rate, the images cannot be output as fast as they are created by the sensor, resulting in dropped frames which are irretrievably lost!

If the REC OUT frame rate is higher than the sensor frame rate, duplicate frames are output on the REC OUT. For example, if the sensor is running at 10 fps and the REC OUT is set to 30 fps, every image is output 3 times, resulting in two duplicate frames following every active frame.

Note: ALEXA does currently not support Variframe recording!

The recorder would record these duplicate frames, which have to be removed in post.

The MON OUT should match the sensor and the REC OUT frame rate. If the sensor frame rate exceeds the available MON OUT frame rates, set the MON OUT to half the sensor frame rate if possible. This minimizes risk of jittering image movements.

How to correctly set frame rates for recording with external devices:

- Decide which frame rate you want to set
- In the Homescreen of the camera display, press the FPS screen button.
- In the Fps screen, press the REC OUT screen button. This opens the REC OUT menu screen.
- Set the REC OUT frame rate to the desired value. The HD-SDI format should match the recorder's setting
- If the desired sensor frame rate is a standard speed, set "Link sensor fps" to "On". This way, the sensor always follows the REC OUT frame rate, avoiding dropped or duplicate frames.
- When the REC OUT settings are done, press BACK to load the Sensor Fps screen.
- In the Sensor Fps screen, decide if the MON OUT frame rate is OK. If not, press the MON OUT screen button. This loads the MON OUT menu screen.
- Set the MON OUT frame rate to the desired value. If the sensor frame rate exceeds the available MON OUT frame rates, set the MON OUT to half the sensor frame rate if possible.
- When the MON OUT settings are done, press the BACK button to load the Sensor fps screen.
- Choose the desired sensor fps value from the list and press the jogwheel.

- If the desired value is not available, press the ADD screen button to set the desired value and add it to the list by pressing the jogwheel.
- All frame rate settings should be correct now.

11.1.4.3 SHUTTER

Pressing the SHUTTER screen button in the HOMESCREEN opens the SHUTTER list screen. The list contains default shutter angles 11.2, 22.5, 45.0, 90.0, 172.8, 180.0, 270.0 and 358.0.

Note: Access to this screen is disabled during record.

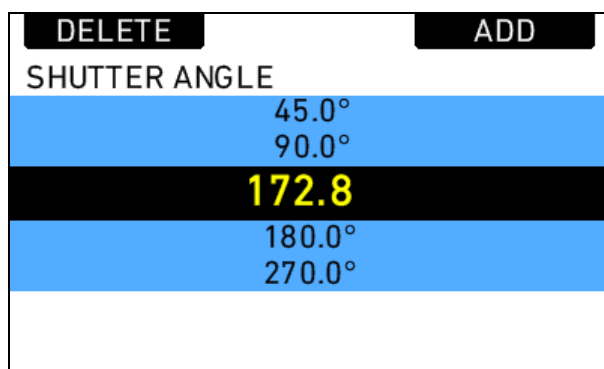

Figure 42: Shutter list

To add a new entry to the list, press the ADD button. This opens the Set shutter screen.

In this screen, the new list entry can be set with the jogwheel. With the screen buttons the value can be in- or decreased in bigger steps. Any shutter angle in the range of 5.0-358.0 degrees can be set.

First set the integer value with the jogwheel, clicking it will start edit on the fractional part.

Note: A maximum of 16 entries is supported by the list. After reaching this number of entries, it is no longer possible to add entries without deleting others first.

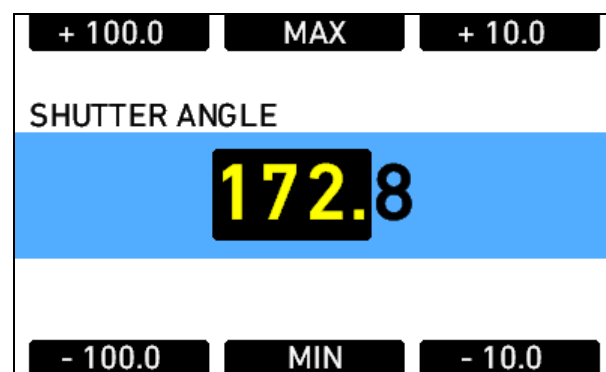

Figure 43: Add Shutter angle

Press the DELETE button to delete list entries. Entries must first be selected with wheel. Deletion must be confirmed by pressing the two lower screen buttons simultaneously. After deletion, the SHUTTER list screen is loaded, and a new value must be selected.

Note: Default values cannot be deleted.

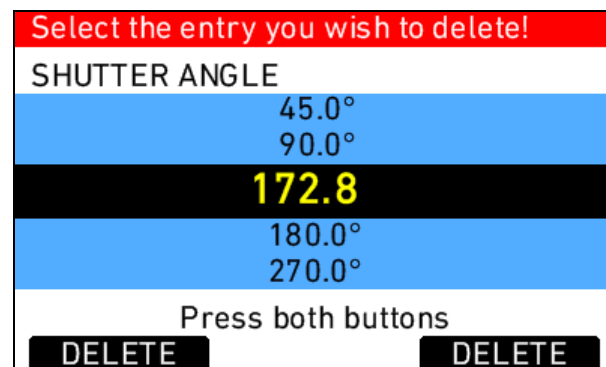

Figure 44: Shutter list delete screen

11.1.4.4 EI

The Exposure Index is the applied sensitivity of the camera.

Note: The Exposure Index list has a fixed content, meaning that it cannot be changed by the user.

ALEXA has a basic sensitivity of 800 ASA. This means that the dynamic range is evenly distributed above and below neutral grey with very low noise in the blacks and a very screen clipping behavior in the whites.

Due to its high dynamic range, the sensitivity can be set in a range from 160-1600 ASA in steps of 1/3 stops while keeping a high image quality.

Applying the extreme ASA ratings will nonetheless have an influence on the images. At low ASA ratings like 160 ASA, the dynamic range below neutral grey gets bigger, which will reduce noise even further. At the same time, the dynamic range above neutral grey is slightly reduced. The clipping itself is not influenced by this, but the shoulder of the gamma curve will get slightly steeper, which will reduce the smoothness of the clipping.

At high ASA ratings like 1600 ASA, the images behave the opposite way. Noise is increased, which makes it important to judge the dark parts of the image, while the clipping behavior will be even smoother.

EXPOSURE INDEX
500 ASA
640 ASA
800 ASA
1000 ASA
1280 ASA

Figure 45: Exposure Index screen

11.1.4.5 WB

White Balance adjusts the color balance of the camera according to the lighting in use.

The WB list presets are 3200K for Tungsten, 4300K for Fluorescent and 5600 for Daylight. The white balance can be adjusted in steps of 100K from 2000 to 11000K.

In addition to the white balance, which influences only the red-blue balance of the image, the CC (color compensating) shift can also adjust the green-magenta balance.

Any light source that does not have a continuous spectrum, like fluorescent tubes, will have peaks in its spectrum that can not be corrected with the traditional white balance.

The CC shift can correct these peaks up to the same amount of a full green or a full magenta gel.

DELETE	RENAME	ADD
WHITE BALANCE		
	Tungsten	3200K 0CC
	Fluorescent	4300K 0CC
	Daylight	5600K 0CC

Figure 46: White balance list

If the list lacks the required setting, press the ADD screen button. This opens a screen where the desired setting can be set. Either use the jogwheel to set the desired value, or additionally use the screen buttons for bigger adjustment steps. The lower right screen button can be used to toggle between WB and CC values. Confirming the desired setting with the jogwheel adds a new entry to the list.

1 step of CC SHIFT translates to 035 Kodak CC values or 1/8 Rosco values.

Note: A maximum of 16 entries is supported by the list. After reaching this number of entries, it is no longer possible to add entries without deleting others first.

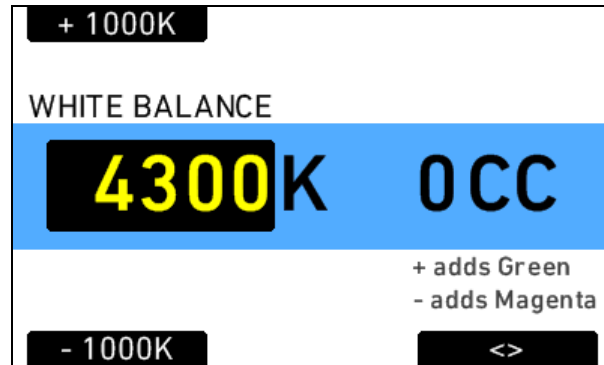

Figure 47: Ad WB screen

White balance and color compensation should be adjusted only with the help of appropriate equipment. This can either be a color meter or a vectorscope together with a calibrated grey card.

List values no longer required can be deleted by pressing the DELETE screen button. This opens a screen where the values desired for deletion can be selected with the jogwheel. To delete the selected value, press the two lower outer screen buttons simultaneously.

Note: Default values cannot be deleted.

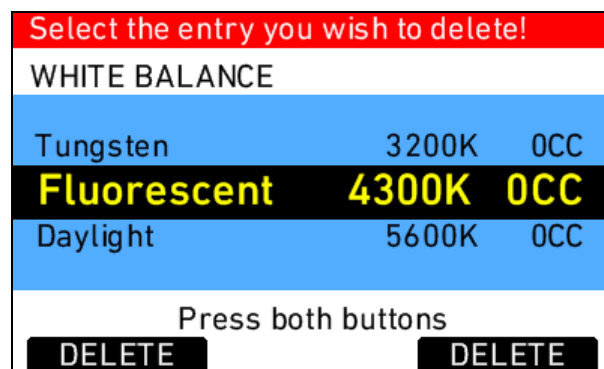

Figure 48: Delete WB list entry

11.1.5 Menu

The menu contains parameters for the basic camera setup. It has a tree structure and the current path in the menu is displayed in the top section of every screen.

To access a new menu level, select the group with the jogwheel and press the jogwheel. This will open the next level.

To go one level back up, press BACK. A parameter has its value displayed at the right part of the screen. Select it with the jogwheel and press the jogwheel to edit it.

Cancel an edit action by pressing BACK, confirm the setting by clicking the jogwheel.

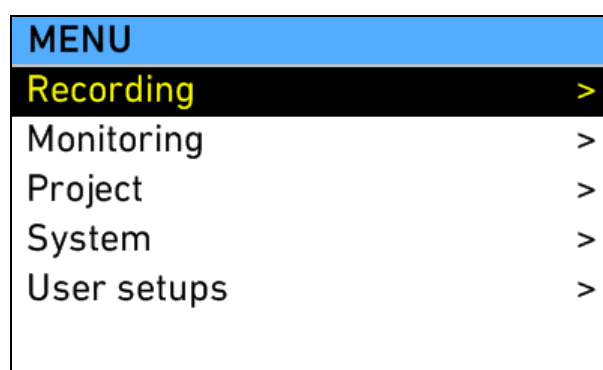

Figure 49: MENU

11.1.5.1 Recording

Provides access to SxS CARDS and REC OUT and allows setting the gamma of the recorded images.

- Gamma defines the contrast curve that is applied to the images. The user can choose between Rec 709 video and Log C (no matrix).
 - Rec 709 video: Gamma according to ITU.R-BT709 standard. Images are prepared for playback on standard broadcast monitors
 - Log C (no matrix): Gamma according to Cineon specification. Images are prepared for output to film material or DI-like treatment. Images will appear flat on a standard broadcast monitors, the use of external devices to apply a LUT, such as TCube, is a must to get visually pleasing images on a monitor.

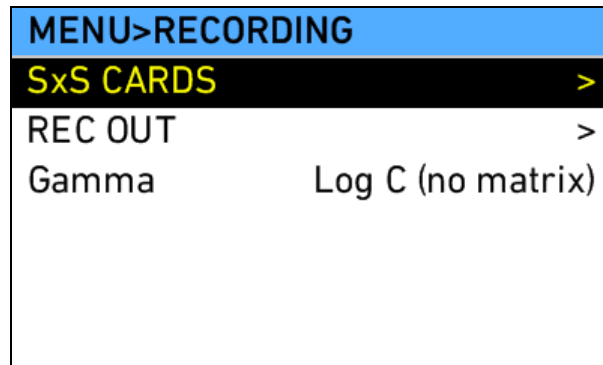

Figure 50: MENU>RECORDING

SxS CARDS

ALEXA can internally record to Sony SxS-Pro cards. The card slots are located on the camera's left side.

- Codec: Set the codec to be used for internal recording to **SxS** cards. Choose from the full range of Apple ProResTM codecs.

Name	Color coding	Data rate (@ 30 fps)	Recording time on 32 GB SxS-Pro @ 30 fps	max. frame rate**
ProRes 422 (Proxy)	YCbCr	45 Mb/s	1 h 35 min	30 fps
ProRes 422 (LT)	YCbCr	102 Mb/s	42 min	30 fps
ProRes 422	YCbCr	147 Mb/s	29 min	30 fps
ProRes 422 (HQ)	YCbCr	220 Mb/s	19 min	30 fps
ProRes 4444*	RGB*	330 Mb/s*	12 min	30 fps

*Without alpha channel (444 only)

**The camera is currently limited to 30 fps maximum frame rate for internal recording

- Format SxS CARD 1/Format SxS CARD 2: Opens a screen where the SxS cards can be formatted. Formatting is only enabled if the write protection of the card is switched off. The write protection cannot be switched off while the card is mounted in the camera!

Note: Formatting an **SxS** card removes all data irreversibly from the card. Be careful not to format any SxS cards with data before they have been backed up!

When cards without a valid file system are inserted into the camera, a screen will appear that asks for card formatting. It is recommended to directly format the card and not to postpone this action.

REC OUT

The camera has two HD-SDI outputs that carry the camera image to be recorded with external recording devices.

- Frame rate: The range of frame rates that can be set depends on the active HD-SDI format. See following table for frame rates and formats of REC OUT.
- HD-SDI format: Select the format that is used to transmit images. See following table for format details.

Format	Links Used	Image Raster	Sampling Structure	Color Mode	Possible Frame Rates (fps)
422 1.5G	1	1920x1080	4:2:2	YCbCr	23.976, 24, 25, 29.97, 30
422 1.5G DL	2	1920x1080	4:2:2	YCbCr	48, 50, 59.94, 60
444 1.5G	2	1920x1080	4:4:4	RGB	23.976, 24, 25, 29.97, 30
T-Link 1.5G	2	2880x1620* *	Bayer**	Bayer* *	23.976, 24, 25, 29.97, 30

**Note: The RAW sensor image is transmitted wrapped as 1920x1080 RGBA. This signal can only be recorded with Arriraw T-Link certified recorders.

Note: 3G formats are currently deactivated.

- Scan format: Defines how images are transmitted.
 - p: Progressive. Images are transmitted line by line from left to right, starting at the top-left pixel.
 - psf : Progressive segmented. Images are first split into fields, which are then transmitted line by line from left to right.
-

Note: Frame rates over 30 fps are only available in progressive scan. this

complies with SMPTE standards.

- Output range: Defines which bit range of the full 10 bit (0-1023) is used to transmit image data.
 - Legal: Uses values 640-940 for RGB and Y signals, and values 64-960 for CbCr signals. This complies with the SMPTE 274M 8.7.
 - Extended: uses values 5-1019, which results in about 10% more steps. Complies with SMPTE 274M 8.12 (called undershoot/overshoot).

Note: Check which mode your recorder supports. If you set the camera to extended, but your recorder only supports legal, you will end up with clipped images!

- Link sensor to REC OUT: If set to "On", the sensor will always follow the REC OUT frame rate setting. This ensures no frames are dropped on the output.

MENU>RECORDING>REC OUT	
Frame rate	24 fps
HD-SDI format	444 1.5G
Scan format	psf
Output range	Legal
Link sensor to REC OUT	Off
SDI remote	Off

Figure 51: MENU>REC OUT

- SDI remote: When set to On, the REC OUT and MON OUT will carry a flag in their data stream to signal an external recorder if the camera is currently recording internally.

Note: Only use double shielded HD-SDI cables for recording to ensure error free data transmission!

High-speed recording with ALEXA over HD-SDI

Unlike the ARRIFLEX D-21, which used a proprietary mode for high-speed recording, ALEXA complies with SMPTE standard 372M in terms of image transmission.

This means that images are split into fields, and every field is transmitted over one link. The second field of every image is transmitted over the other link, so that every link carries an interlaced signal in field integration mode. The recorder realigns the images correctly into a progressive sequence.

11.1.5.2 Monitoring

The Monitoring section defines setup of EVF-1 electronic viewfinder and MON OUT. These outputs are meant for monitoring, not for recording of images.

The frame lines setup applies to both MON OUT and EVF-1. Frame lines can of course be switched on or off individually for MON OUT and EVF-1.

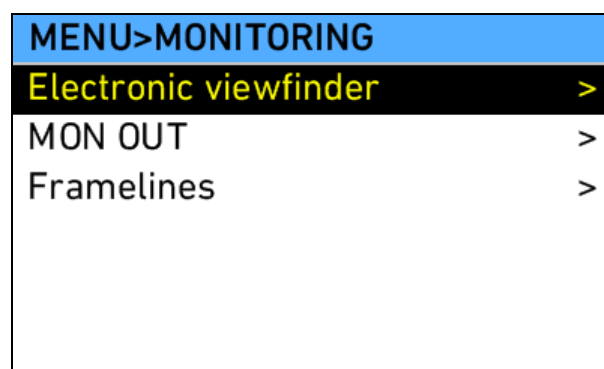

Figure 52: MENU>MONITORING

Electronic Viewfinder

- **Brightness:** Select the brightness of the EVF. A level of 5 is recommended for normal circumstances.
- **White point:** Sets the color temperature of the EVF. Default is 6500K. Can either be matched to the white point of other monitoring devices on set, or to match the white point of the illumination source. **NOT TO BE MISTAKEN WITH THE WHITE BALANCE OF THE CAMERA!**
- **Rotate image:** When mounting the EVF to the right side of the camera, the image can be flipped so it appears correctly in the viewfinder. Affects only the EVF image, MON OUT and recording images are not rotated!
- **Surround view:** The ALEV III sensor has 10% additional pixels outside the recorded image for a better monitoring experience. The user can decide whether he wants to see these 10% in the viewfinder or not. By switching surround view on, objects that are not wanted in the image, such as microphone booms, can be seen by the operator before they enter the image.
- **Frame lines:** Frame lines are a reference for framing that typically consist of an image frame, a center mark and an aspect ratio reference. See the appendix for more information on the ALEXA frame line format.

- Status info: At the upper and lower edge of the EVF, right outside the active image area, additional status info can be displayed. The upper area contains camera image parameters, the lower area contains camera status infos.

MENU>MONITORING>EVF	
Brightness	0
White point	6500K
Rotate image	Off
Surround view	On
Frame lines	Off
Status info	On

Figure 53: MENU>MONITORING>EVF

MON OUT

The MON OUT is a 422 1.5G single link HD-SDI output. The output range is fixed to legal range.

- Frame rate: The MON OUT frame rate can be set to 23.976, 24, 25, 29.97 or 30 fps. The frame rate should, if possible, match the sensor frame rate to avoid frame drops or duplicate frames on the output, which would result in jittering images when image content is moving.
- Scan format: Defines how images are transmitted.
 - P: Progressive. Images are transmitted line by line from left to right, starting at the top-left pixel.
 - Psf: Progressive segmented. Images are first split into fields, which are then transmitted line by line from left to right.
- Gamma defines the contrast curve that is applied to the images. The user can choose between REC 709 video and Log C (no matrix).
 - REC 709 video: Gamma according to ITU.R-BT709 standard. Images are prepared for playback on standard broadcast monitors
 - Log C (no matrix): Gamma according to Cineon specification. Images are prepared for output to film material or DI-like treatment. Images will appear flat on a standard broadcast monitors, the use of external devices to apply a LUT, such as TCube, is a must to get visually pleasing images on a monitor.

Note: Log C (no matrix) can only be chosen if the Recording gamma is set to Log C (no matrix).

- Surround view: The ALEV III sensor has 10% additional pixels outside the recorded image for a better monitoring experience. The user can decide whether he wants to see these 10% in the MON OUT or not. By switching surround view on, objects that are not wanted in the image, such as microphone booms, can be seen by the operator before they enter the image.
- Frame lines: Frame lines are a reference for framing that typically consist of an image frame, a center cross and an aspect ratio reference. See the appendix for more information on the ALEXA frame line format.
- Status info: At the upper and lower edge of the MON OUT image, additional status info can be overlayed to the image. The upper area contains camera image parameters, the lower area contains camera status infos.

MENU>MONITORING>MON OUT	
Frame rate	24 fps
Scan format	psf
Gamma	Rec 709 video
Surround view	On
Frame lines	On
Status info	On

Figure 54: MENU>MONITORING>MON OUT

Note: Only use double shielded HD-SDI cables for monitoring to ensure error free data transmission!

Frame Lines

Frame lines are an image overlay that can be applied to either the EVF image, the MON OUT image, or both.

ALEXA frame lines are stored as XML files containing definitions what the frame lines look like.

The camera contains default frame lines for 1.33:1, 1.78:1, 1.85:1 and 2.35:1 aspect ratios. Additional frame lines can be loaded from the SD card.

- Frame lines: Shows a list of all frame lines currently stored in the camera.
- Color: In the frame lines definition file, lines can either be given a fixed color, or they can have the color specified as "User". If "User" is chosen for a line, the setting chosen in this menu section is applied to the line.

Note: Default frame lines have "User" specified as color for all content.

- Intensity: Sets the intensity of the frame lines. The higher the number, the brighter the frame lines appear.

M>MONITORING>FRAMELINES	
Frame lines	ARRI-178
Color	Red
Intensity	2
Manage frame lines	>

Figure 55: MENU>MONITORING>FRAMELINES

Manage Frame Lines

- Load frame lines from SD: Loads all frame lines contained on the SD card to the camera.
- Reset to default frame lines: Deletes all frame lines in the camera and then loads the ARRI default frame lines.
- Delete camera frame lines: Deletes all frame lines currently stored in the camera.

M>MON>FRAMELINES>MANAGE
Load frame lines from SD
Reset to default frame lines
Delete camera frame lines

11.1.5.3 Project

- Project fps: Sets the timebase of the time code, which determines how many frames the time code counts per second. Also sets the frame rate of Quicktime clips recorded to SxS cards during playback.
- Camera index: Identifies camera unit in clips. Influences clip names on SxS cards.

- Next reel count: Counter assigned to the next new card used for recording. Automatically increased by the camera. Influences clip names on SxS cards.

Note: The user should set the value to 001 before a shoot begins.

- Camera ID prefix: The first letter of the Camera ID can be changed between L and R for stereoscopic productions to identify left and right eye camera. Influences naming of clips on SxS cards.

MENU>PROJECT	
Project frame rate	24 fps
Camera index	A
Next reel count	001
Camera ID prefix	L

Figure 56: MENU>PROJECT

11.1.5.4 System

Contains groups of system settings.

MENU>SYSTEM	
Power	>
Display	>
System clock/date	>
Run beeper	>
Firmware	>

Figure 57: MENU>SYSTEM

Power

- BAT1 (Plug) warning: The level at which a power warning is exhibited for the power source connected to the BAT plug. Can be adjusted to match the used battery type. Default value is 21.0V.
- BAT2 (Onboard) warning: The level at which a power warning is exhibited for the onboard battery. Can be adjusted to match the used battery type. Default value is 12.0V.

Note: At a level 10% below the set warning level, a battery error is emitted. This

means that the power source is treated as insufficient to power the camera any further.

MENU>SYSTEM>POWER	
BAT1 (Plug) warning	21.0V
BAT2 (Onboard) warning	12.0V

Figure 58: MENU>SYSTEM>POWER

Smart batteries that transmit their remaining load to the camera emit a warning at 10% remaining capacity and an error at 5% remaining capacity. Currently batteries by ID-X and Anton Bauer support this feature.

Display

- Display brightness: Set the brightness of the camera right side LCD display. The brightness can also be adjusted when the Homescreen is active by turning the jogwheel.
- Button brightness: Set the brightness of the button illumination.

MENU>SYSTEM>DISPLAY	
Display brightness	0
Button brightness	Off

Figure 59: MENU>SYSTEM>DISPLAY

System Clock/Date

Set date and time of the camera to match your current location.

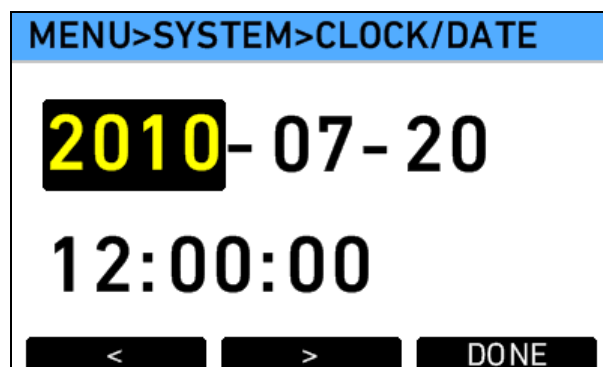

Figure 60: MENU>SYSTEM>CLOCK/DATE

Use the lower screen buttons to navigate between the elements in the screen and to finish your setting.

Run beeper

The camera has a beeper to acoustically signal the start and/or stop of recording.

Firmware

- Select update file: If an SD card containing update files is inserted in the camera, you can select an update file from the list and perform an update. Start the update procedure by pressing the two lower outer screen buttons simultaneously. DO NOT INTERRUPT THE UPDATE ONCE IT HAS STARTED. MAKE SURE THE CAMERA POWER SUPPLY WILL REMAIN SUFFICIENT FOR THE DURATION OF THE UPDATE (APP. 15 MINUTES).

Note: On rare occasions, the update process can fail. If the update procedure fails, try it again until you succeed.

- Current version: Release code of currently installed firmware.

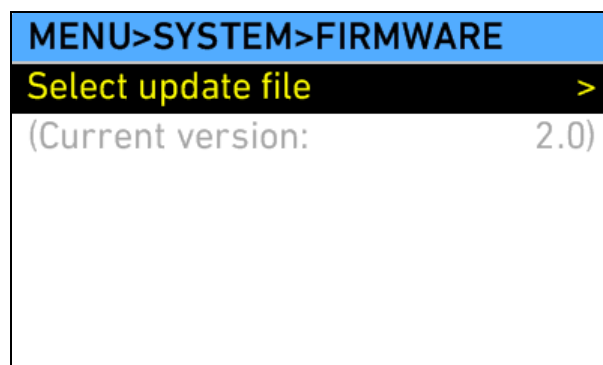

Figure 61: MENU>SYSTEM>FIRMWARE

11.1.5.5 User Setups

In this section the user can store the current setup to the SD card or load previously stored setups from the SD card. An SD card must be present in the camera to perform these operations. Only complete camera setups can be stored or loaded!

Note: It is recommended to create a default starting setup to load into any new camera you work with. This way you can ensure all parameters meet your expectations.

- **Save current setup:** A setup containing the current camera settings is stored to the SD card. File is named with time and date stamp.
- **Load setup:** Loads a list with all setups located on the SD card. Select a setup and load it.

Note: Before loading or saving a setup, make sure an SD card is present. When saving a setup, the write protection of the SD card must be switched off.

- **Factory reset:** Resets the camera to factory defaults. Confirm factory reset by pushing the two lower outer screen buttons simultaneously when the request appears.

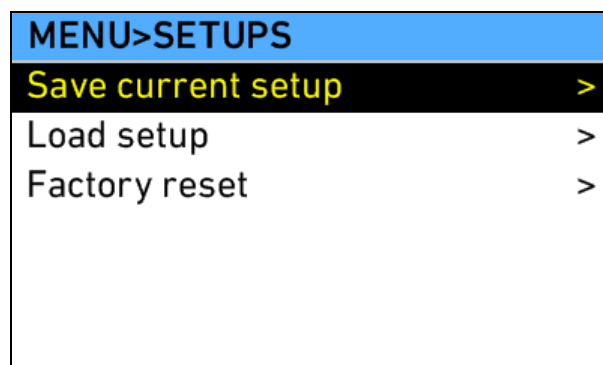

Figure 62: MENU>SETUPS

11.2 Operator controls

The operator controls are located on the camera left side and consist of three function buttons plus three assignable buttons.

- **1, 2, 3:** The assignable buttons (labeled 1, 2, 3) can be assigned with functions through the USER button on the main UI.
- **REC:** starts and stops internal recording. LED tally goes red during record.
- **PLAY:** loads a list of all clips on the mounted SxS cards. Playback from cards is currently not possible.

- **LOCK:** long pressing of the button locks the main and the operator controls. LED indicates if lock is active. Long pressing again deactivates the locking.



Figure 63: Operator UI

11.3 EVF Controls

The EVF controls are located on the electronic viewfinder. They consist of a number of function buttons and a jogwheel.

- **CAM:** opens the viewfinder CAM menu
- **EVF:** opens the viewfinder EVF menu.
- **ZOOM:** zooms into the image with a 2.25x magnification for focus checking. This results in matching one sensor pixel to one viewfinder pixel. Zoom remains active as long as button is pressed. To keep it activated, press the EXP button while the ZOOM button is pressed. The ZOOM function will remain activated until the ZOOM button is pressed again.
- **EXP:** changes the EVF gamma from Rec 709 video to Log C (no matrix) as long as the button is pressed. To keep it activated after the button press, press the ZOOM button while the EXP button is pressed. The log gamma will remain active until the EXP button is pressed again.

Note: This only works when the Recording gamma is set to Log C (no matrix). If the Recording gamma is set to Rec 709 video, the EVF gamma is always set to Video.



11.3.1 Viewfinder EVF menu

Pushing the EVF button opens a menu in the EVF display to set the viewfinder parameters. Select the setting to be changed with the jogwheel, press the wheel and set it to the desired value. Press again to confirm. To quit the menu, press the EVF button.

- **Brightness:** Select the brightness of the EVF. A level of 5 is recommended for normal circumstances.
- **White point:** Sets the color temperature of the EVF. Default is 6500K. Can either be matched to the white point of other monitoring devices on set, or to match the white point of the illumination source. **NOT TO BE MISTAKEN WITH THE WHITE BALANCE OF THE CAMERA!**
- **Rotate image:** When mounting the EVF on the camera right side, the image can be flipped so it appears upright in the viewfinder. Affects only the EVF image, MON OUT and REC OUT are not affected!
- **Surround view:** The ALEV III sensor has 10% additional pixels outside the recorded image for a better monitoring experience. The user can decide whether he wants to see these 10% in the viewfinder or not. By switching surround view on, objects that are not wanted in the image, such as microphone booms, can be seen by the operator before they enter the image.
- **Status info:** At the upper and lower edge of the EVF, right outside the active image area, additional status info can be displayed. The upper area contains camera image parameters, the lower area contains camera status infos.
- **Frame lines:** Frame lines are a reference for framing that typically consist of an image frame, a center cross and an aspect ratio reference. See the appendix for more information on the ALEXA frame line format.
- **Select frame lines:** Choose a frame lines file from those stored in the camera.

Note: Switching surround view ON and frame lines OFF is a dangerous combination, as there is no indication in the EVF image that it shows more than is recorded, which can lead to framing errors.

11.3.2 Viewfinder CAM menu

Pressing the CAM button on the EVF opens the cam menu. The settings displayed in the top bar section of the viewfinder can be adjusted.

These are: Sensor Fps, Shutter Angle, Exposure Index and White Balance.

The values that can be chosen mirror the content of the respective lists in the main UI. Select the setting to be changed with the jogwheel, press the jogwheel to open the list. Select a list value and press the jogwheel again. To quit the menu, press the CAM button.

12 Operation of The Camera

This chapter describes what has to be done overall to perform a certain task. It contains the necessary hardware setup and camera configuration to perform the task.

12.1 Recording

12.1.1 Internal recording

This chapter contains information and recommendations for recording with **SxS** cards. The user is of course free to modify the recommended worksteps to his needs.

Note: ARRI cannot be held responsible for the loss of any data in conjunction with internal recording!

ALEXA can internally record on Sony **SXS**-Pro cards. These cards have an ExpressCard34 form factor and are currently available with 8, 16, 32 or 64 GB storage space.

Card file format

SxS cards have to be formatted in the camera before they can be used for recording. ALEXA uses an UDF file system. This file system is read-only for computers, which means data can be copied from the card to another device, but the data cannot be manipulated on the card itself.

Card preparation

The typical usage cycle of a card is: Format - Record - Copy - Backup - Verification - Format

- **Format:** Before recording, cards have to be formatted in the camera. The camera always performs a blank format, which means that the cards contain no meta data and are not assigned a reel number prior to recording the first clip. The camera auto-detects cards with a wrong file system and asks the user to format the card. ALEXA uses an UDF file system. This file system is read-only for computer systems, which minimizes the risk of data corruption.
- **Record:** When pressing the REC button, the camera starts to write a clip to the card. With the first clip, the card is assigned a reel number. More information on file naming later in this chapter.
- **Copy:** After recording to the card is finished, either because it is full, or for any other reason, the data should be copied to another device to minimize the risk of data loss. Also, the data should be verified after copying through checksums to ensure that no error has occurred during the copy process.
- **Backup:** The data should actually be copied to two physically separate destinations, with the first copy being the "working copy", and the second copy being the "Backup". These two copy processes can be done in parallel, as long as the result are two independent devices containing the verified data.
- **Format:** Only when the data has been copied and verified to two independent devices, the card should be formatted to remove all data from it. It is also recommended that the card is formatted by the person that has verified the copy and backup, so that the camera crew only receives empty cards. This functions as a security check, so that the crew is alerted if they receive a card with valid data on it, which might not have been copied and backed up. The card can be formatted with any file system, as it has to be reformatted by the camera anyway.

Codec

The Apple ProRes codec family consists of 5 different codecs:

Name	Color coding	Data rate (@ 30 fps)	Recording time on 32 GB SxS-Pro @ 30 fps	max. frame rate**
ProRes 422 (Proxy)	YCbCr	45 Mb/s	1 h 35 min	30 fps
ProRes 422 (LT)	YCbCr	102 Mb/s	42 min	30 fps
ProRes 422	YCbCr	147 Mb/s	29 min	30 fps
ProRes 422 (HQ)	YCbCr	220 Mb/s	19 min	30 fps
ProRes 4444*	RGB*	330 Mb/s*	12 min	30 fps

*Without alpha channel (444 only)

**The camera is currently limited to 30 fps maximum frame rate for internal recording

Selecting the codec that fits best for the shoot is a crucial task. Choosing a codec with a high data rate, such as ProRes 4444, delivers the highest image quality, but at the same time lowers the available recording time on an **SxS** card.

- ProRes 422 (Proxy): On-set monitoring and proxy editing while the master is captured with an external device.
- ProRes 422 (LT): Same as above when higher image quality is desired
- ProRes 422: Basic television application, if images do not require adjustments in post production
- ProRes 422 (HQ): High quality TV applications requiring color correction
- ProRes 4444: Cinema applications requiring color correction and pulling mattes

If possible, the full workflow pipeline with the preferred codec should be tested before a shoot.

Card file format

SxS cards have to be formatted in the camera before they can be used for recording. ALEXA uses an UDF file system. This file system is read-only for computers, which means data can be copied from the card to another device, but the data cannot be manipulated on the card itself.

CARD file structure

SxS cards are named ARRI UDF after they are formatted in the camera until the first clip is record. Clips are stored in a folder named exactly like the card. In addition to the clips, an XML file named like the card and the folder extended by _FCP (example: A001R1JL_FCP.xml) is created by the camera. The XML file is according to the FinalCutPro XML specification. If the XML file is opened in FinalCutPro directly from the card, all clips are imported as one bin into FCP. If the clips are copied from the card to another destination, the file paths in the XML file have to be adjusted to match the new file location.

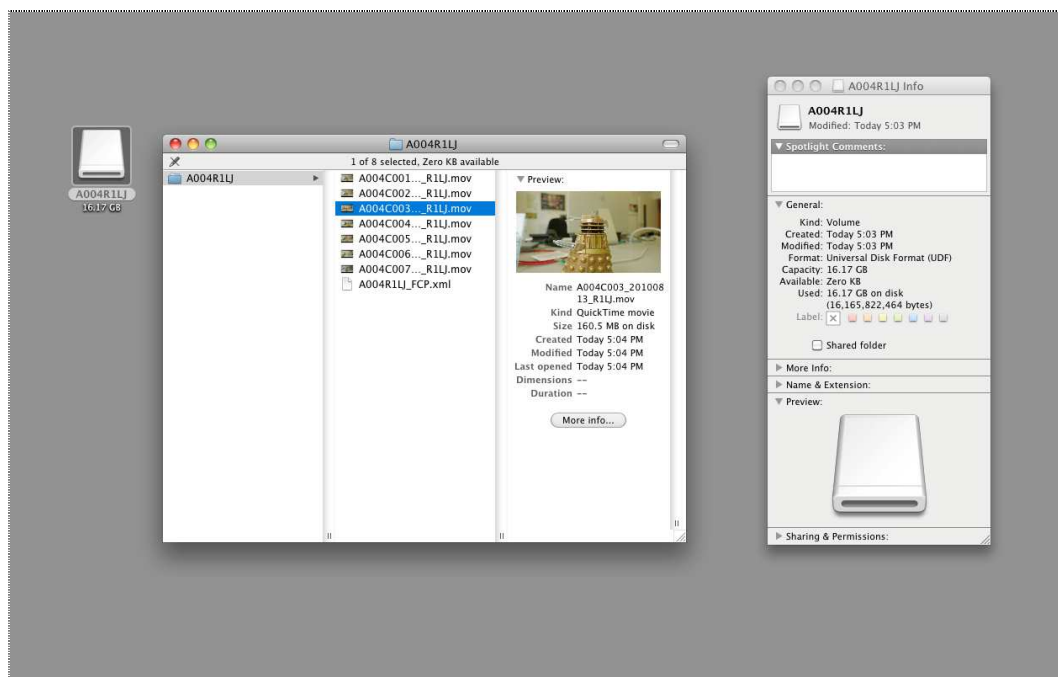

Figure 64: Screenshot of ALEXA SxS card under Mac OS X

File naming scheme

ALEXA automatically names files as they are created on the SxS card. While it is possible to change the file names later on a computer, it is not recommended, as the ALEXA naming scheme has been developed to minimize the risk of duplicate file names.

The file name consists of 6 parts:

- Camera Index: One character, A-Z. User assignable, should match the camera unit.

- Reel Counter: 3 characters, 001-999. Auto-assigned to each card, increased by one for each new card. The user can change the counter to be given to the next card. This should only be done on special occasions, like after changing the camera body in the middle of a shoot.
- Clip Index: One character, fixed to C. Main use is to separate the reel counter from the clip counter. If more than 999 clips are recorded to one card (not likely to happen), it changes to D.
- Date: Current date, in order YYYYMMDD, as set in Menu>System/Time/Date
- Camera ID: Consists of a 1 letter prefix, user adjustable between R and L, and the camera serial number encoded in 3 letters Base36 (0-9, A-Z).

The date is separated by underscores at the start and the end.

The reel counter shall be set to 001 at the start of a shoot. The camera will then automatically increase the reel counter whenever a card is recorded for the first time after formatting. If a previously recorded card is used again (comparable to a short end of a film roll), this card will keep its reel count and the camera will remember how far it has counted. If the reel counter has to be changed by the user, it can be done via Menu>Project>Next reel count. Note that this is only recommended for special occasions.

Example

A typical file name could look like this:

A004C010_20100610_R1JL.mov

What it tells the user is that this clip was the tenth clip recorded on the fourth card used. It was recorded on the 10th of June 2010, and the camera had the Base 36 serial number 1JL, which translates into the decimal serial number 2001 (Plenty of Base 36 to decimal converters can be found on the Internet, for example here:

<http://www.translatorscafe.com/cafe/units-converter/numbers/calculator/decimal-to-base-36/>

<http://www.translatorscafe.com/cafe/units-converter/numbers/calculator/decimal-to-base-36/>).

Additional recommendations

To ensure correct card handling and reduce the risk of data loss, ARRI recommends the following procedure for card and data handling:

- Pre-format cards. Format all available cards in the camera before the shoot starts. This reduces downtime during production caused by the need to format. Cards do not receive a reel counter before the first clip is recorded to them, so there is no need to record the cards in a certain order. Formatting a 32 GB card usually takes less than 10 seconds.

- Limit card recording time. Codecs with lower data rates like Pro Res 422 (Proxy) can be recorded for quite a duration onto SxS cards with high capacities. Users should consider limiting the recording time per card to a maximum of 30 minutes of material as it is easier to handle and reduces the impact on the production in case of a problem.
- Immediately copy the data after a card change. The data should be in a single instance for the shortest time possible.
- Switch on write protection when a card has been recorded and is sent to the copy instance.
- Switch off write protection when data has been copied and backed up, then format the card.

Metadata

Metadata is stored in the index.xml file as well as the quicktime file header. Most important for the post production workflow is the tape name, as it will be one of the main image identifiers in an EDL. Even though tape name is not quite a good name for nonlinear media, it is used due to post production naming conventions. Alternatively, reel name is used sometimes.

The tape name of ALEXA files is limited to 8 letters to match the CMX 3600 EDL standard. It consists of the Camera Index, reel counter and the Camera ID.

The tape name of the clip from the previous example would then be: A004R1JL.

Even if the user forgets to assign different camera indices to two cameras on one shoot, the Camera ID guarantees unique tape names.

Currently one time code track is recorded in the quicktime file.

12.1.2 External recording

Uncompressed HD and unprocessed ARRIRAW data is available via the REC OUT for recording with external devices.

The preferred output format also depends on the application. As a rule of thumb, the following guideline can be used:

- 422 1.5G: Television applications that only require color correction, high-speed capture above 30 fps
- 444 1.5G: High-quality television applications that require color correction and pulling mattes, cinema applications
- ARRIRAW: High-quality cinema applications for multi-format distribution

422 1.5G YCbCr

422 is a color sub-sampled format, meaning that the camera-native RGB image is transformed to YCbCr color space. Y represents luminance, while Cb and Cr are color difference signals. These are sampled with only half the horizontal resolution, as the human eye is less sensitive to color resolution than to luminance resolution. As a result, bandwidth is saved in transmission while receiving good visual results.

For frame rates up to 30 fps, 422 1.5G is transmitted over 1 HD-SDI cable. Frame rates higher than 30 fps require 2 cables.

444 1.5G RGB

444 is still in the RGB color space, and each color has its full resolution. This is important when pulling chroma keys, as these rely on color resolution.

444 1.5G is transmitted over 2 HD-SDI cables, where each of both links carries a part of the image data. It is important to

- connect REC OUT "A" of the camera with REC IN "A" and REC OUT "B" of the camera with REC IN "B" of the recorder
- use cables of equivalent lengths for link A and B

ARRIRAW

ARRIRAW is the name of raw data from ARRI cameras. Raw data is the sensor image data before it is converted to RGB images. As ALEXA has a single sensor with a Bayer pattern color filter array, this means that every pixel only has information of one color channel.

With normal HD images, the missing color channel information is calculated from the adjacent pixels in the camera.

For raw data, this calculation is delayed until after the recording to save bandwidth and creative options, as many decisions on how to convert the images can be made in post.

ALEXA ARRIRAW specs:

- Bayer pattern color coding
- 12 bit log luminance coding
- No white balance applied
- No exposure index applied
- Full sensor resolution (2880x1620)

ARRIRAW is transmitted to the recorder via the ARRIRAW T-Link by using a standard HD-SDI dual link connection with a proprietary coding. An ARRIRAW T-Link certified recorder must be used for recording. These are available from a number of manufacturers like Codex, Keisuko Giken or S.Two.

For more information, go to www.arri.de/arriraw

Note: Only use double shielded HD-SDI cables on all HD-SDI outputs to ensure error free data transmission!

12.1.3 Parallel recording

Recording to both **SxS** cards and external devices at the same time requires additional attention from the user. First, it has to be determined what function the two sets of data have. For example, the internal recording could be used for on-set review and proxy editing, while the external device captures the master data. Or the internal recording is used for TV utilization and the external recorder captures ARRIRAW for cinematic use.

Remote controlling the external recorder

By activating the "SDI remote" in the REC OUT menu screen, it is possible to control external recorders if they support this feature. This is only possible while recording to an **SxS** card.

Note: There is no feedback channel providing information to the camera if the external recording is active - make sure to check the external recorder directly!

Timecode on external recorders

To guarantee the same Timecode for images that are parallelly record internally and externally, set the external recorder so that it uses the TC embedded in the HD-SDI stream coming from the camera.

12.2 Monitoring

The electronic viewfinder and the MON OUT can be used for monitoring purposes. They can both display the surround view area, an extra 10% of image outside the recorded area to track any unwanted objects before they enter the image.

To help the framing, both EVF-1 and MON OUT can overlay frame lines to the image. these frame lines are an electronic version of the ground glass of analog cameras.

12.2.1 Framelines

Frame lines are stored as XML files. A standard set of frame lines is stored in each camera. In addition, the user can create personal frame lines matching his preferences.

Once the idea behind the frame lines system is understood, personal frame lines can be created with little effort.

Description

The different sections in the file are:

- camera: describes the camera that the frame lines file is made for. As the ALEXA camera system will consist of several cameras in the future, this is necessary to differentiate between the camera types.
- surround: the 10% surround view area outside the recorded image.
 - opacity: opaque masking of the surround area, 0=transparent, 1=black
 - border: additional frame around the image if surround view is switched on in EVF or MON OUT image, with attributes color and width. Omit the border tag if you do not want the frame around the image.
- line: all frame lines and the center cross in the active image area consist of single lines. The line orientation is defined by three attributes (left and right and bottom or top for horizontal lines, top and bottom and left or right for vertical lines), where two attributes define the start and end point, and the third defines the distance from the parallel image edge.
- Distances for start, end and position are relative to the width or the height of the image and have a precision of 5.
- To create a centered frame line with a center cross as in the example, a total of 6 lines is necessary.
- To calculate the position of a line for a given aspect ratio, use the following formulas:
 - horizontal lines for aspect ratios >1.78 (e.g. 1.85): $[1 - (1.78/\text{Aspect})]/2 = \text{distance from bottom or top}$
 - vertical lines for aspect ratios <1.78 (e.g. 1.33): $[1 - (\text{Aspect}/1.78)]/2 = \text{distance from left or right}$

XML example

The best way to understand the frame lines system is by looking at an example. The following example describes a frame lines file for a 2.35 centered aspect ratio inside the cameras 1.78 recorded image.

```
<?xml version="1.0" encoding="UTF-8"?>
<!-- NOTES:
  All widths are in pixels.
  All colors can be one of: black, white, or user.
  If you select user, the color can be changed through
  the user interface.
  You can add as many lines as you like. Lines are
  defined by giving 3 distances from the border.
  So if you specify top, left and right it will
  be a horizontal line with the given distance
  from left, right and from the top.
  The values are in the range [0, 1], where:
    0 is at the edge
    1 is on the opposite edge
  So specifying 0.4 from left is the same as 0.6 from right.
-->
<framelines>
  <!-- The description of the camera, this will
    only be used for selecting the correct files.
    So the user can only select glasses for his
    camera/current setup. -->
  <camera>
    <type>Alexa EV</type>
    <sensor>3K</sensor>
    <aspect>1.78</aspect>
    <hres>2880</hres>
    <vres>1620</vres>
  </camera>

  <!-- This describes the surround view (or overscan) area.
    You can select the opacity in the range [0, 1] with discrete steps 0,
    0.25, 0.5, 0.75
    and the border width and color -->
  <surround>
    <opacity>0.5</opacity>
    <!-- If you omit the border tag no border is shown -->
    <border>
      <!-- This is the width in pixels. No
        pixel is drawn in active/visible area. -->
      <width>4</width>
      <!-- The color can be one of: black,
        white or user. If you select user,
        the color can be changed through the
        user interface. -->
      <color>user</color>
    </border>
  </surround>

  <!--user color line at top and bottom of 2.35 aspect-->
  <line>
    <left>0</left>
    <top>0.12174</top>
    <right>0</right>
    <width>4</width>
    <color>user</color>
  </line>
  <line>
    <left>0</left>
    <bottom>0.12174</bottom>
    <right>0</right>
    <width>4</width>
    <color>user</color>
  </line>
```

```

<!-- Center cross horizontal lines, user color -->
<line>
    <left>0.46355</left>
    <top>0.5</top>
    <right>0.50868</right>
    <width>4</width>
    <color>user</color>
</line>
<line>
    <left>0.50868</left>
    <top>0.5</top>
    <right>0.46335</right>
    <width>4</width>
    <color>user</color>
</line>
<!-- Center cross vertical lines, user color -->
<line>
    <left>0.5</left>
    <top>0.43519</top>
    <bottom>0.51543</bottom>
    <width>4</width>
    <color>user</color>
</line>
<line>
    <left>0.5</left>
    <top>0.51543</top>
    <bottom>0.43519</bottom>
    <width>4</width>
    <color>user</color>
</line>
</framelines>

```

12.3 Using Time code

The purpose of Time code is to ensure that each image stored on one medium has a unique value through which it can be identified. By doing this in combination with correct reel naming, which is to ensure that each storage medium used in a production has a unique name, each image acquired in a production can be identified uniquely.

There are many different ways how Timecode can be used in a production. The 2 most common ways are presented as examples.

External TC, Time of day

- **Use:** This format is often used on multi-camera productions with sync-sound. The cameras are running on a sync-sound speed, which is also the project frame rate. if done correctly, sound and image time code should match and allow an easy alignment in post.
- **Setup:** The sound department acts as the Time code master, and generates a Timecode which uses the Time of day as a value, and the time base is the project frame rate. 24 hours of time will translate into 24 hours of Time code.

This Time code is fed to the camera via the LTC in. The camera must be set to Ext LTC Free Run, and the project fps setting must match both the sensor frame rate and the time base of the external TC signal. Then the camera can either use Jam sync mode, in which it samples the TC value once and then continues counting based on its own high-precision crystal clock, and the TC signal can be disconnected from the camera after jamming. This mode ensures stable time code with an offset of less than 1 frame for 8 hours, after which the camera has to be re-jammed. Or the camera can be set to Regenerate mode, where the camera uses the TC value of the external TC signal. This ensures correct CT for an infinite duration, but the TC signal must remain connected to the camera.

- **Variations:** If the shooting starts close to midnight, the TC might be started with an offset to prevent a rollover at midnight.
- **Restrictions:** Only possible if the camera is running at sync-sound speed. If the camera is over- or under-cranking, the TC frame rate will no longer match the sensor frame rate, so that TC values would either be duplicate or dropped. Due to this reason, the camera will automatically switch to Int TC Regen, when the sensor frame rate is changed.

Internal TC, Rec Run

- **Use:** Single camera productions, either MOS or where a classical slate is used for alignment of image and sound. Guarantees continuous time code for each storage medium. Works also with over- and under-cranking.
- **Setup:** The camera is set to Int TC Rec Run Regen. TC is only increased during record by 1 frame for each image generated by the sensor. The TC counts with the project fps set on the camera as time base. Normally, the TC hour value is increased by 1 hour for each new reel, using only hours 01-20 for reel 1-20, and then restarting at hour 01 for reel 21.
- **Variations:** Might be used on a production normally using external TC for high-speed scenes, then returning to Ext TC for regular scenes later.
- **Restrictions:** None.

12.4 Working with User Setups

Appendix

In this appendix

Technical specifications	92
Camera Dimensions	95
ALEXA Camera Accessory List	96
Infos and Warnings	98

12.5 Technical specifications

Image Sensor

Type	ALEV III CMOS sensor
Sensor frame rates	0.750 - 60.000 fps
Shutter angle	5.0° - 358.0°
Total active pixels (incl. surround view)	3112 x 1782
Pixels of recorded image	2880 x 1620
Aperture of recorded image	23.76 x 13.365 mm
Image aperture (incl. surround view)	25.674 x 14.701 mm
Pixel pitch	8.25 µm
Aspect ratio	1.78:1 (16:9)
Filters	optical low pass, UV, IR
Color filters	RGB primary colors

Lens

Lens mount	Exchangeable lens mount, with PL mount LA-PL-1 installed
------------	--

Image processing

White balance	2000 - 11000 Kelvin
CC Shift	-8 to +8 (translates to full magenta/ full green gel correction)
EI rating	160-1600 ASA
Recorded image resolution	1920 x 1080 pixels (downscaled from 2880 x 1620)

Viewfinder

Type	ARRI EVF-1
Technology	LCOS imaging device
Resolution	1280 x 784 pixels

Power

Power supply	DC 11-34V
Power management	Active ORing between BAT connector and onboard battery adapters
Power consumption	ca. 85W w/o accessories
Power outputs	2 x RS (24V), 1x 12V

Recording

Recording media	Sony SxS -Pro cards
Recording compression codec	Apple ProRes 422/4444 codec family
Frame rates	0.75-30 fps

Image Outputs

Recording output	<p>2x REC OUT configurable as:</p> <p style="padding-left: 40px;">2x 422 1.5G YCbCr @ frame rates: 23.976, 24, 25, 29.97 and 30 fps</p> <p style="padding-left: 40px;">or 1x 444 1.5G RGB @ frame rates: 23.976, 24, 25, 29.97 and 30 fps</p> <p style="padding-left: 40px;">or 1x 422 1.5G DL YCbCr @ frame rates: 48, 50, 59.94 and 60 fps</p> <p style="padding-left: 40px;">or 1x ARRIRAW T-Link @ frame rates: 23.976, 24, 25, 29.97 and 30 fps</p>
Monitoring outputs	<p>EVF out: proprietary signal for EVF-1 with delay<1 frame</p> <p>1x MON OUT: 1x 422 1.5G @ frame rates: 23.976, 24, 25, 29.97 and 30 fps</p>

Timecode

Type	TC clock generator with crystal oscillator
TC input	LTC in
TC outputs	LTC out HD-SDI LTC/VITC out

Dimensions and weight

Length x Width x Height (body)	329 x 158 x 153 mm
Camera body weight	6.26 kg / 13.79 lb
Camera setup weight (incl. EVF-1, VMB-1, CCH-1)	8.0 kg / 17.62 lb
Others	SD card slot for FAT/FAT32 SD cards Fan module with noise level <20 dB(A) @ 24 fps and ambient temperature < 25° C Lemo Ethernet port for remote control and firmware updates

12.6 Camera Dimensions

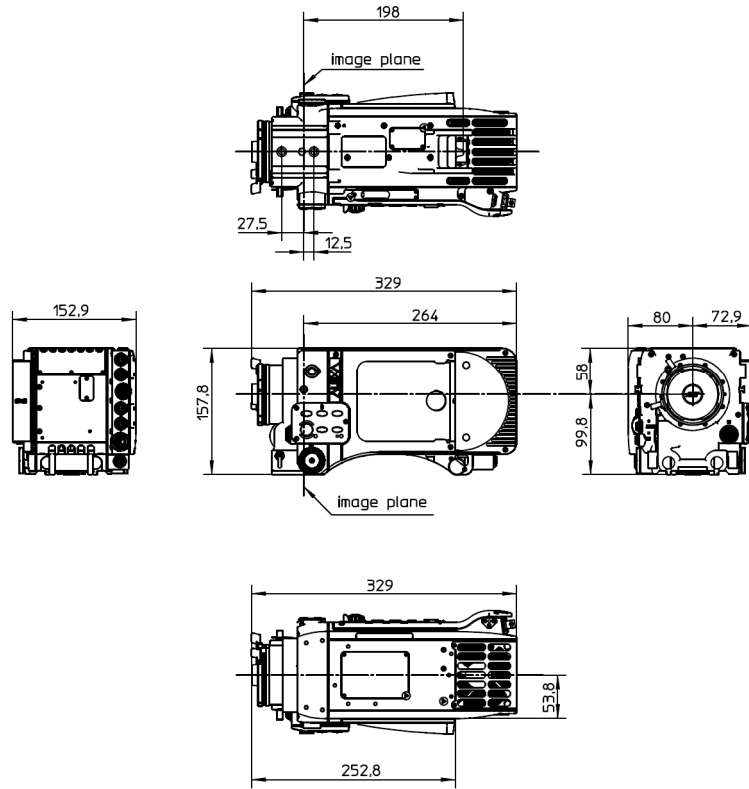

A.1 ALEXA Camera Accessory List

Name	Model#	Ident#
SxS Pro Card	-	K2.72019.0
SD Card 2 GB	-	K2.72018.0
Electronic Viewfinder	EVF-1	K2.72008.0
Viewfinder Mounting Bracket	VMB-1	K2.72009.0
Viewfinder Extension Bracket	VEB-1	K2.72000.0
Viewfinder Cable Short (0.35m/1.2ft)	KC 150-S	K2.72012.0
Viewfinder Cable Medium (0.65m/1.2ft)	KC 151-S	K2.72013.0
Viewfinder Cable Long (2.00m/6.6ft)	KC 152-S	K2.72014.0
ALEXA Ethernet/RJ-45 Cable (3.00m/9.8ft)	KC 153-S	K2.72021.0
ALEXA Ethernet/Ethernet Cable (2.0m/6.6ft)	KC 156-S	K2.72033.0
ALEXA External Remote Cable (2.0m/6.6ft)	KC 155-S	K2.72032.0
ALEXA 12V Accessory Cable	KC 154-SP-S	K2.72031.0
Battery Adapter Top for Gold-Mount	BAT-G	K2.72006.0
Battery Adapter Top for V-Lock	BAT-V	K2.72011.0
Battery Adapter Back for Gold-Mount	BAB-G	K2.72003.0
Battery Adapter Back for V-Lock	BAB-V	K2.72010.0
UMC Connection Cable (0.80m/2.6ft)	K-UMC3- ALEXA	K2.65239.0
Spare Fan Module	SFM-1	K4.72117.0
ALEXA Case	-	K2.72030.0
Bridge Plate Set	BP-12 Set	K0.71031.0
Bridge Plate	BP-12	K2.72004.0
Wedge Adapter	WA-1	K2.72002.0
Bridge Plate Adapter	BPA-1	K2.72001.0
Leveling Block	LB-1	K2.72017.0

Shoulder Pad	SP-3	K2.72005.0
Center Camera Handle	CCH-1	K2.72007.0
Side Camera Handle	SCH-1	K2.72016.0
Adjustable Center Grip Tall	ACG-2	K2.72022.0
Handle Extension Block	HEB-2	K2.72015.0
Low Mode Support Set	LMS-3	K2.72023.0
ALEXA Rain Protector	ARP-1	K2.72026.0
Lens Adapter Panavision Mount	LA-PV-1	K2.72020.0
Air Drying Cartridge	-	K2.70110.0

12.7 Infos and Warnings

If anything unwanted occurs in the camera, it will give a message to the user.

These states, that require attention from the user, are indicated by icons in the main display, the viewfinder and the MON OUT.

Warnings are message that inform the user that a state has changed or that an error might occur soon. Anyway, recording is still possible.

If the camera goes into error state, recording is no longer possible, as it cannot be guaranteed that images are acquired as the user intended, or recording is simply not possible.

The messages give a compact info what has happened. if more information is required, please refer to the following tables.

Special warnings and errors: Sensor temperature

ALEXA has a Peltier element that keeps the image sensor at a stable temperature. This is important to achieve constant image quality. Under some occasions, the camera might not be able to keep this temperature, or it might take some time to reach the correct level. This can be the case right after booting, or with very hot or cold ambient temperatures.

A red temperature icon indicates that the sensor temperature is too far off to guarantee a high image quality, while a white temperature icon indicates that image quality is still in the (very high set) quality limits required by ARRI.

The related messages in the INFO screen are shown in the following tables.

ALEXA status message

System state: Good Everything works fine. Relax.

ALEXA warning messages and meanings

Warning message	Meaning
Main Bat: Power warning	The battery attached to the BAT connector has reached its warning level. Battery power is about to end, and a replacement battery should be prepared.
Onboard Bat: Power warning	The battery attached to the onboard battery adapter has reached its warning level. Battery power is about to end, and a replacement battery should be prepared.

Card 1: Low capacity	The SxS card in slot 1 has less than 3 minutes recording time left. Prepare a new card for recording.
Card 2: Low capacity	The SxS card in slot 2 has less than 3 minutes recording time left. Prepare a new card for recording.
Card 1: Rec protected	The SxS card in slot 1 is Rec protected. Remove the card from the camera, slide the switch located on the camera back end to the Rec enable position and re-insert the card.
Card 2: Rec protected	The SxS card in slot 2 is Rec protected. Remove the card from the camera, slide the switch located on the camera back end to the Rec enable position and re-insert the card.
Card 1: Full	SxS card in slot 1 is selected, but the SxS card is full. Use a new card. Card in other slot can still record.
Card 2: Full	SxS card in slot 2 is selected, but the SxS card is full. Use a new card. Card in other slot can still record.
Card 1: Wrong file system	The SxS card in slot 1 is not formatted in the file system required by the camera. Format the card.
Card 2: Wrong file system	The SxS card in slot 2 is not formatted in the file system required by the camera. Format the card.
Card 1: Card is too slow	The write speed of SxS card in slot 1 is insufficient for the sensor fps set on the camera. Use a card with a higher write speed.
Card 2: Card is too slow	The write speed of SxS card in slot 2 is insufficient for the sensor fps set on the camera. Use a card with a higher write speed.
Camera overheating	The camera system's temperature is reaching a critical level. this can either be due to a blocked camera fan or ambient temperature exceeding the system's limits. Apply additional cooling or switch of the camera to prevent hardware damage.
Low sensor temperature	The sensor temperature is lower than it should be. High image quality is still guaranteed.
High sensor temperature	The sensor temperature is higher than it should be. High image quality is still guaranteed.

External TC: Wrong frame rate	The time base of the TC signal present at the LTC input does not match the camera's project fps.
Re-jam Timecode soon	Accuracy of jammed Timecode can soon expire. Re-jam camera with external Timecode soon.
Re-jam Timecode now	Accuracy of jammed Timecode has expired. Re-jam camera with external Timecode.
TC source forced to internal	Sensor fps does not match Project fps. External Free Run TC cannot be used, camera has switched to Int Rec Run TC.
Interface bit error	Reboot camera. If error continues to occur, contact ARRI service.
Internal processing problem	Reboot camera. If error continues to occur, contact ARRI service.
Internal battery error	The internal battery which powers the real-time clock must be replaced. Contact an ARRI service center near you.
System problem	Reboot the camera. If error continues to occur, contact ARRI service.

ALEXA error messages and meanings

Main Bat: Low power	The battery attached to the BAT connector has reached its low level (10% below warning level). Battery must be replaced.
Onboard Bat: Low power	The onboard battery has reached its low level (10% below warning level). Battery must be replaced.
All Bats: Low power	Batteries on both BAT connector and onboard battery(s) have to be replaced.
Card 1: End of lifetime	The SxS card in slot 1 has reached the end of its life cycle and has become read-only. Use a new card.
Card 2: End of lifetime	The SxS card in slot 2 has reached the end of its life cycle and has become read-only. Use a new card.
Card 1: Write speed error	The current write speed could not be handled by the SxS card in slot 1

Card 2: Write speed error	The current write speed could not be handled by the SxS card in slot 2
Cards 1&2: Full	Both SxS cards are full. Use fresh cards.
Cards 1&2: End of lifetime	Both SxS cards have reached the end of their life cycle and has become read-only. Use fresh cards.
Cards 1&2: Wrong file system	Both SxS cards are not formatted in the file system required by the camera. Format the cards.
Cards 1&2: Rec protected	Both SxS cards are rec-protected. Eject the cards, switch off the protection and re-insert the cards.
Camera overheating	The camera is getting too warm. Apply additional cooling or shut down to prevent hardware damage.
Low sensor temperature	Sensor temperature is out of range. Wait until error message disappears before continuing to shoot.
High sensor temperature	Sensor temperature is out of range. Wait until error message disappears before continuing to shoot.
System error	Reboot the camera.
DTE codec error - Reboot!	An error in the compression module has occurred, and recording was aborted. Reboot the camera before you continue to record!
Sensor error. Reboot!	The image sensor has a problem. reboot the camera.
Sensor boot error!	The sensor has not booted. Reboot the camera.
Fan error. Contact service!	The fan module is not working properly. Either install an SFM-1, or contact the ARRI service.
Fatal system error! Reboot camera now!	Camera has to be rebooted. If this error continues to occur, a hardware problem might be the reason. Contact the ARRI service.

If any error that requires rebooting continues to occur regularly, contact the ARRI service.

13 Index

1

12 V	39
12 V Accessories	24

2

24 V Accessories	24
------------------------	----

3

3.5mm TRS connector (Headphone Jack)	40
--	----

A

About This Manual	12
ALEXA Camera Accessory List	96
ALEXA Images	8
Appendix	91
AUDIO IN	39

B

BAT	38
BAT Connector	19
Bridge Plate adapter BPA-1	33
Bridge Plate BP-12	32

C

Camera Controls	45
Camera Dimensions	95
Camera Side Handle CSH-1	31
Center Handle CCH-1	30
Cine-Style Batteries	19
Condensation	16
Connectors	36

D

Disclaimer	4
Display	46, 74

E

EI	62
Electromagnetic Interference	16
Electronic Viewfinder	69
Electronic Viewfinder EVF-1	26
Ethernet	39
EVF	39
EVF Controls	77
Explanation of Warning Signs and Indications	13
EXT	38
External recording	84

F

Firmware	75
FPS	56
Frame Lines	71
Framelines	87
Function Buttons	46

G

General Precautions	16
General Safety Instructions	13
Gold Mount Batteries	22

H

HOMESCREEN	53
------------------	----

I

INFO	49
Infos and Warnings	98
Installation of The Camera	25
Internal recording	79
Introduction to ALEXA	10

L

Lens Adapter PL Mount LA-PL-1 (no LDS)	42
Lens Support	43
Leveling Block LB-1	34
Lists and User Lists	55

M

Main Controls	45
Mains Unit NG 12/26 R	19
Menu	65

Minimum Equipment Recommended For Operation	25
MON OUT	38, 70
Monitoring	69, 86

O

Onboard Batteries	20
Operation of The Camera	79
Operator controls	76
Optics	42

P

Parallel recording	86
Power	20, 73
Power Management	18
Power Outputs	23
Power Supply	18
Project	72

R

REC OUT	67
REC OUT 1&2	38
Recording	65, 79
RET/SYNC IN	38
RS	39
Run beeper	75

S

Safety Instructions	13
Scope	7
Screen Buttons	46
SD Card	40
Shoulder Pad SP-3	34
SHUTTER	60
Specific Safety Instructions	14
Storage and Transport	16
SxS CARDS	66
SxS Slots	41
System	73
System Clock/Date	75

T

TC	40
TC (Time Code)	47
Technical specifications	92
Tripod and Remote Heads	25

U

USER	51
USER BITS	48
User Setups	76
Using Time code	89

V

Viewfinder Cables	27
Viewfinder CAM menu	79
Viewfinder EVF menu	78
Viewfinder Mounting Bracket	28
V-Mount Batteries	21

W

WB	63
Wedge Adapter WA-1 + Quick-Release Plate	33
Working with User Setups	90